

# Technical Information

## Smartec CLD18

Compact inductive conductivity measurement for the food and beverage industry



### Application

Compact measuring system for inductive conductivity measurement in liquids with medium to high conductivity. The structure is made from highly durable, food-safe polyetheretherketone (PEEK). The excellent chemical resistance properties of the sensor mean it can also be used in applications outside the food industry. The measuring system is perfectly suited for:

- Phase separation of product/water mixtures in the beverage industry
- Control of cleaning-in-place facilities (CIP), concentration control, separation in the cleaning return line
- Industrial water monitoring
- Rinsing processes in pickling plants

### Your benefits

- Hygienic sensor design in accordance with EHEDG and 3-A requirements, no risk of recontamination
- Stainless steel or plastic transmitter housing, IP 69K, can be cleaned with high-pressure steam
- High level of repeatability, 0.5 % of reading, always guarantees same separation or monitoring

## Function and system design

### Measuring principle

#### Inductive conductivity measurement

An oscillator (1) generates an alternating magnetic field in the primary coil (2), which induces a current flow (3) in the medium. The strength of the current depends on the conductivity and thus on the ion concentration in the medium. The current flow in the medium, in turn, generates a magnetic field in the secondary coil (4). The resulting induced current is measured by the receiver (5) and used to determine the conductivity.

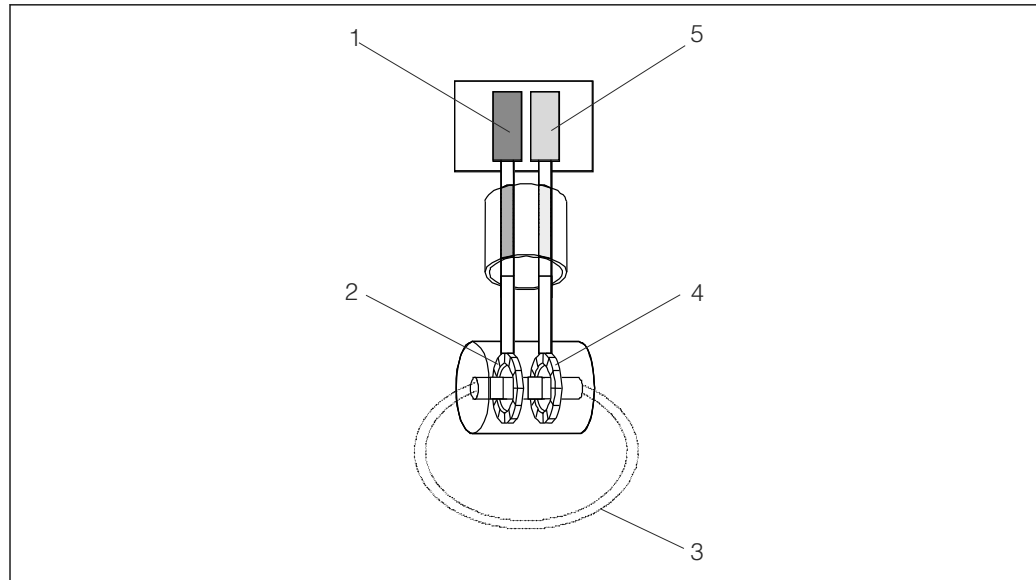

A0004894

#### 1 Inductive conductivity measurement

- 1 Oscillator
- 2 Primary coil
- 3 Current flow in the medium
- 4 Secondary coil
- 5 Receiver

Advantages of inductive conductivity measurement:

- No electrodes and therefore no polarization effects
- Accurate measurement in media with a high degree of pollution and a tendency to form buildup
- Complete galvanic isolation of the measurement and the medium

**Key properties**

- **Hygiene**  
 The PEEK sensor (polyetheretherketone) has excellent chemical, mechanical and thermal resistance properties, is entirely seamless and gap-free and is therefore safe to use in hygienic applications. The sensor has 3A approval which is required for the hygiene sector. All wetted materials are FDA-listed. The sensor has been designed according to the latest guidelines of the American Society of Mechanical Engineers - Bioprocessing Equipment (ASME BPE) and meets the requirements of EC Regulation No. 1935/2004 of the European Parliament on materials and articles intended to come into contact with food.
- **Process connections**  
 The measuring system is available with all the process connections commonly used in the hygiene sector. The measuring system is also available with a G1½ process adapter and 2¼" coupling nut for use in non-hygienic areas.
- **Process temperature, process pressure**  
 The sensor is suitable for continuous operating temperatures up to 110 °C (230 °F). It can be operated up to 130 °C (266 °F) for short periods (max. 60 min) for sterilization phases. The pressure resistance is 13 bar (188 psi) abs up to 50 °C (122 °F).  
 If the PVC process adapter is used, the maximum pressure resistance drops to 9 bar (130 psi) abs at 25 °C (77 °F) and the maximum process temperature drops to 60 °C (140 °F).
- **Temperature measurement**  
 A Pt 1000 temperature sensor is integrated into the sensor. This ensures efficient phase separation at different and quickly changing process temperatures. The temperature sensor is embedded in the PEEK body.
- **Temperature compensation**  
 Linear temperature compensation with user-configurable temperature coefficients  $\alpha$  is implemented in the measuring system.

## Input

<b>Measured values</b>	Conductivity Temperature	
<b>Measuring range</b>	Conductivity:	Recommended range: 200 µS/cm to 1000 mS/cm (uncompensated)
	Temperature:	-10 to +130 °C (+14 to +266 °F)
<b>Temperature measurement</b>	Pt 1000	
<b>Binary input</b>	The binary input is used for measuring range switching.	
	Voltage range	0 V to 30 V
	Voltage HIGH min.	12 V
	Voltage LOW max.	9.0 V
	Current consumption at 24 V	30 mA
	Undefined voltage range	9.0 to 12 V

## Output

<b>Output signal</b>	Conductivity:	0 / 4 to 20 mA, galvanically isolated
	Temperature:	0 / 4 to 20 mA, galvanically isolated
<b>Load</b>	Max. 500 $\Omega$	
<b>Characteristic</b>	Linear	
<b>Signal resolution</b>	Resolution:	> 13 bit
	Accuracy:	$\pm 20 \mu\text{A}$
<b>Alarm output</b>	The alarm output is implemented as an "open collector".	
	Max. current	200 mA
	Max. voltage	30 V DC
	Error or device without supply voltage	Alarm output blocked (0 mA)
No error	Alarm output open (up to 200 mA)	

## Power supply

### Electrical connection

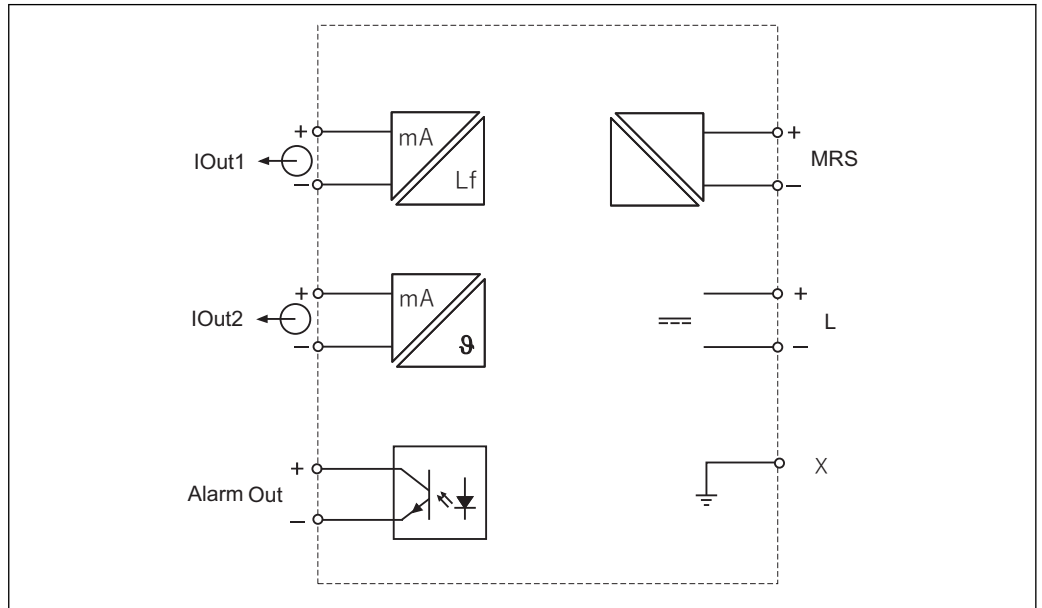

A0019115

2 Electrical connection

### Terminal assignment

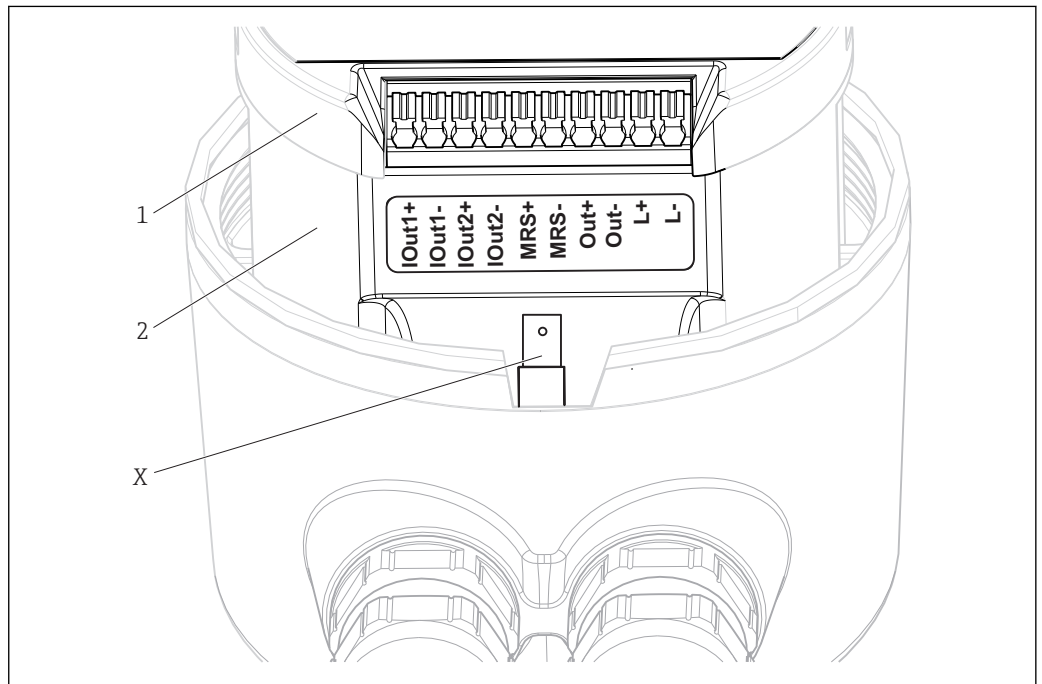

A0029684

3 Terminal assignment

IOut1	Current output conductivity
IOut2	Current output temperature
Out	Binary input (measuring range switch)
MRS	Alarm output (open-collector)
L+/L-	Power supply
X	Grounding pin (flat male tab 4.8 mm)
1	Cover on electronics box
2	Electronics box

### Supply voltage

24 V DC  $\pm 20\%$ , protected against reverse polarity

---

**Power consumption** 3 W

---

<b>Cable specification</b>	Recommendation	0.5 mm <sup>2</sup>
	max.	1.0 mm <sup>2</sup>

## Performance characteristics

---

<b>Response time</b>	Conductivity:	t <sub>95</sub> < 1.5 s
	Temperature:	t <sub>90</sub> < 50 s

---

<b>Maximum measured error</b>	Conductivity:	± (2.0 % of measured value + 20 µS/cm)
	Temperature:	± 1.5 K
	Signal outputs	± 50 µA

---

<b>Repeatability</b>	Conductivity:	max. 0.5 % of measured value ± 5 µS/cm ± 2 digits
----------------------	---------------	---

---

**Cell constant** 11.0 cm<sup>-1</sup>

---

<b>Temperature compensation</b>	Range	-10 to +130 °C (+14 to +266 °F)
	Types of compensation	<ul style="list-style-type: none"> <li>■ None</li> <li>■ Linear with user-configurable temperature coefficient</li> </ul>

---

**Reference temperature** 25 °C (77 °F)

## Installation

### Installation instructions



For a 3-A compliant installation, the following must be noted:

After the instrument is installed its hygienic integrity shall be maintained. The instrument shall be installed with the leakage detection at the lowest point of the assembly. Furthermore all process connections must be 3-A compliant.

The sensor must be completely immersed in the medium. Avoid air bubbles in the area of the sensor.

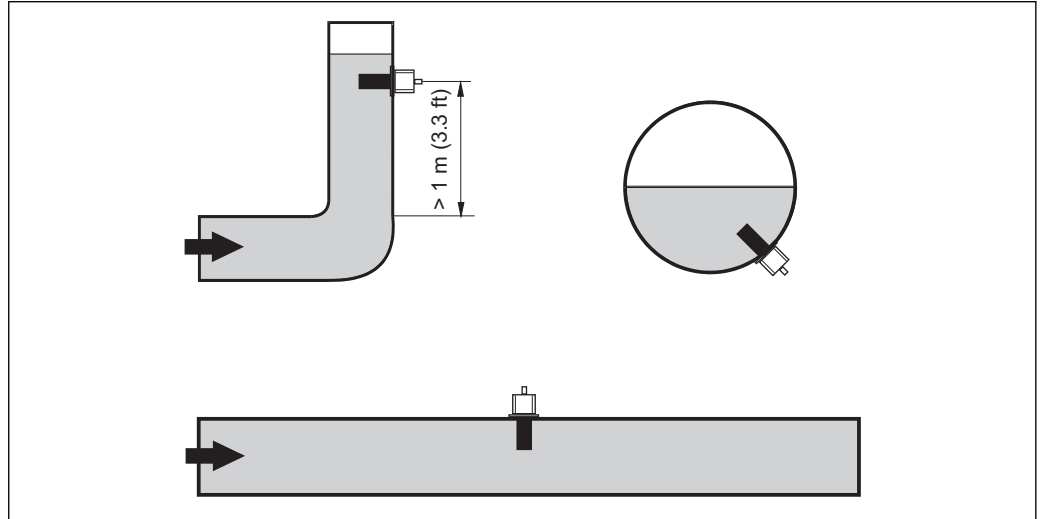

A0017691

4 Orientation of conductivity sensors



If the flow direction changes (after pipe bends), turbulence in the medium can result. Install the sensor at a distance of at least 1 m (3.3 ft) downstream from a pipe bend.

The product should flow along the hole of the sensor (see the arrows on the housing). The symmetrical measuring channel allows flow in both directions.

The ionic current in the liquid is affected by the walls in confined installation conditions. This effect is compensated by what is referred to as the installation factor. The installation factor can be entered in the transmitter for the measurement or the cell constant is corrected by multiplying by the installation factor.

The value of the installation factor depends on the diameter and the conductivity of the pipe nozzle as well as the distance  $a$  between the sensor and the wall.

The installation factor can be disregarded ( $f = 1.00$ ) if the distance to the wall is sufficient ( $a > 20$  mm, from DN 60).

If the distance to the wall is smaller, the installation factor increases for electrically insulating pipes ( $f > 1$ ) and decreases for electrically conductive pipes ( $f < 1$ ).

It can be measured using calibration solutions, or a close approximation can be determined from the following diagram.

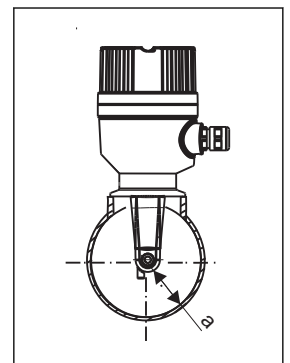

A0018962

5 Installation of CLD18

$a$  Wall distance

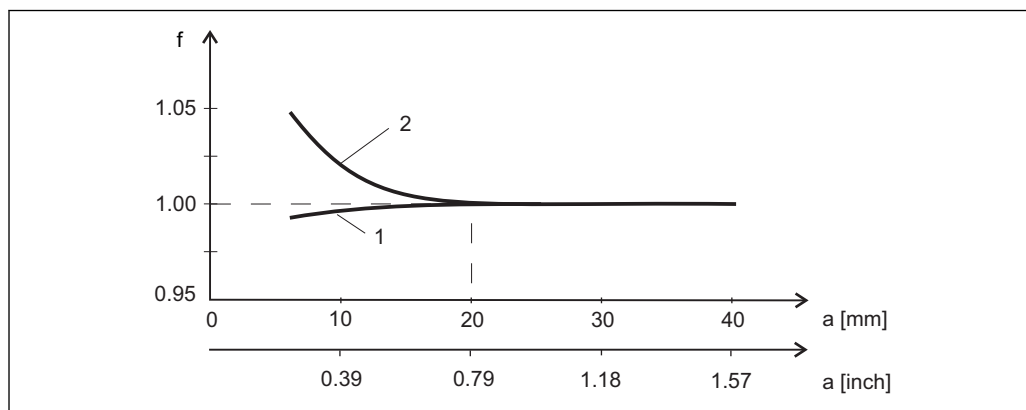

A0020517

6 Relationship between installation factor  $f$  and wall distance  $a$

- 1 Electrically conductive pipe wall
- 2 Electrically insulating pipe wall

**i** Install the measuring system in such a way that the housing is not exposed to direct sunshine.



## Environment

<b>Ambient temperature range</b>	Stainless steel process connection: PVC process connection:	-20 to +60 °C (-4 to +140 °F) -10 to +60 °C (14 to 140 °F)
<b>Storage temperature</b>	Stainless steel process connection: PVC process connection:	-25 to +80 °C (-13 to +176 °F) -10 to +60 °C (14 to 140 °F)
<b>Humidity</b>	≤ 100 %, condensating	
<b>Climate class</b>	Climate class 4K4H as per EN 60721-3-4	
<b>Degree of protection</b>	IP 69k as per EN 40050:1993 Degree of protection NEMA TYPE 6P as per NEMA 250-2008	
<b>Shock resistance</b>	Complies with IEC 61298-3, certified up to 5 g	
<b>Vibration resistance</b>	Complies with IEC 61298-3, certified up to 5 g	
<b>Electromagnetic compatibility</b>	Interference emission as per EN 61000-6-3:2007 + A1:2011 and EN 55011:2009 + A1:2010 Interference immunity as per EN 61326-1:2013	

## Process

<b>Process temperature</b>	Stainless steel process connection: -10 to +110 °C (14 to 230 °F) Max.130 °C (266 °F) up to 60 minutes PVC process connection: -10 to +60 °C (14 to 140 °F)
<b>Absolute process pressure</b>	Stainless steel process connection: 13 bar (188.5 psi), abs to up to 50 °C (122 °F) 7.75 bar (112 psi), abs at 110 °C (230 °F) 6.0 bar (87 psi), abs at 130 °C (266 °F) max. 60 minutes 1 to 6 bar (14.5 to 87 psi), abs in CRN environment tested with 50 bar (725 psi) PVC process connection: 9 bar (130.5 psi), abs to up to 50 °C (122 °F) 6.0 bar (87 psi), abs at 60 °C (140 °F) 1 to 6 bar (14.5 to 87 psi), abs in CRN environment tested with 50 bar (725 psi)

**Pressure-temperature ratings**

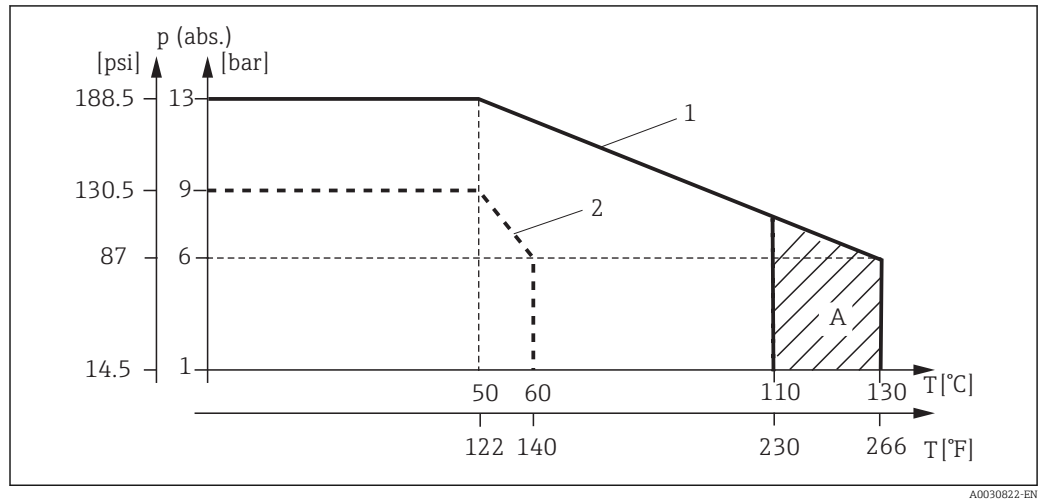

7 Pressure-temperature ratings

1 Stainless steel process connection

2 PVC process connection

A Process temperature increased briefly (max. 60 minutes)

**Flow velocity**

max. 10 m/s (32.8 ft/s) for low-viscosity media in pipe DN 50

## Mechanical construction

### Design and dimensions

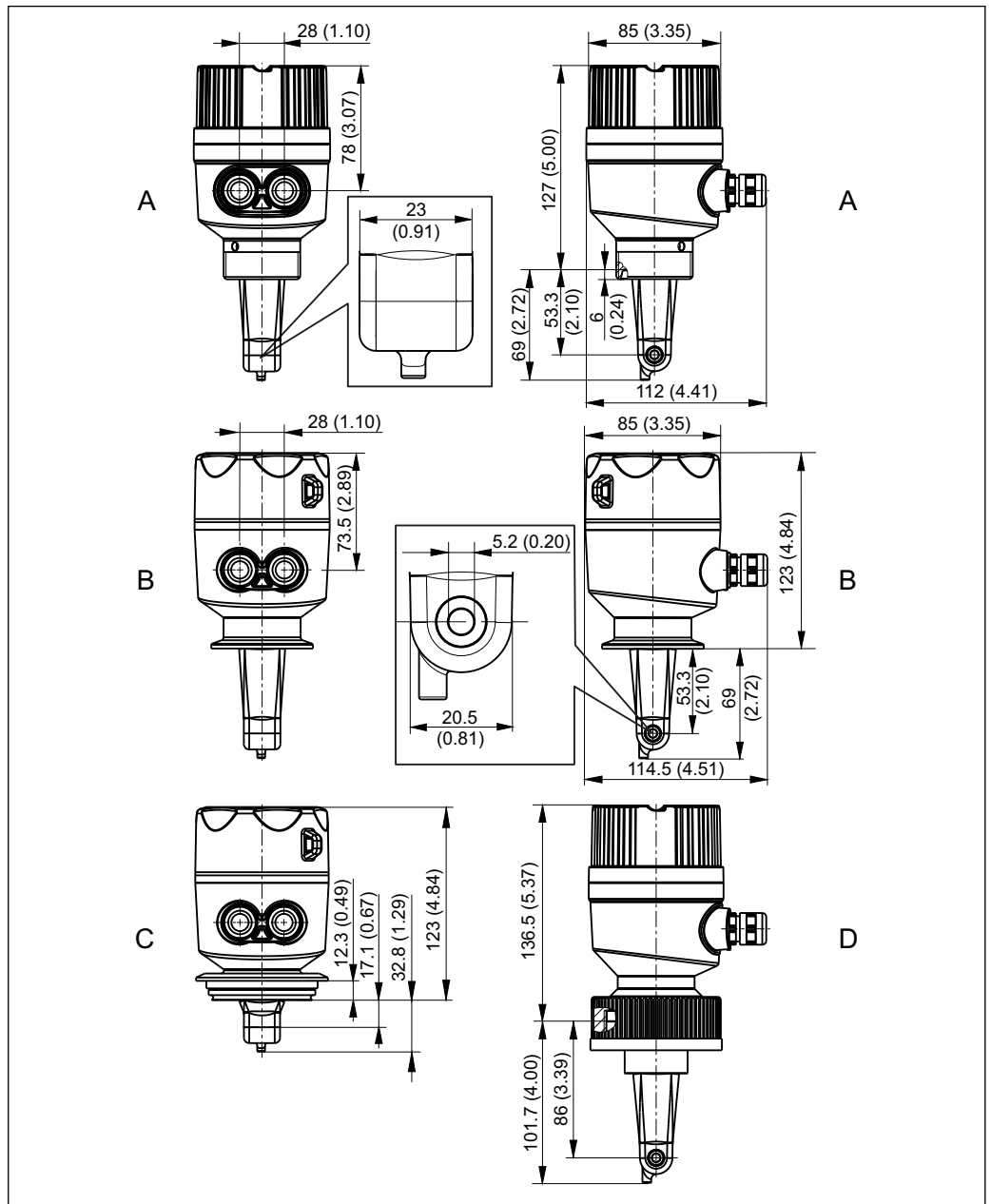

A0018942

8 Dimensions in mm (inch) and versions (examples)

- A Plastic housing with thread G 1½
- B Stainless steel housing with ISO 2852 clamp 2"
- C Stainless steel housing with Varivent DN 40 to 125
- D Plastic housing with coupling nut 2¼" PVC

Process connections

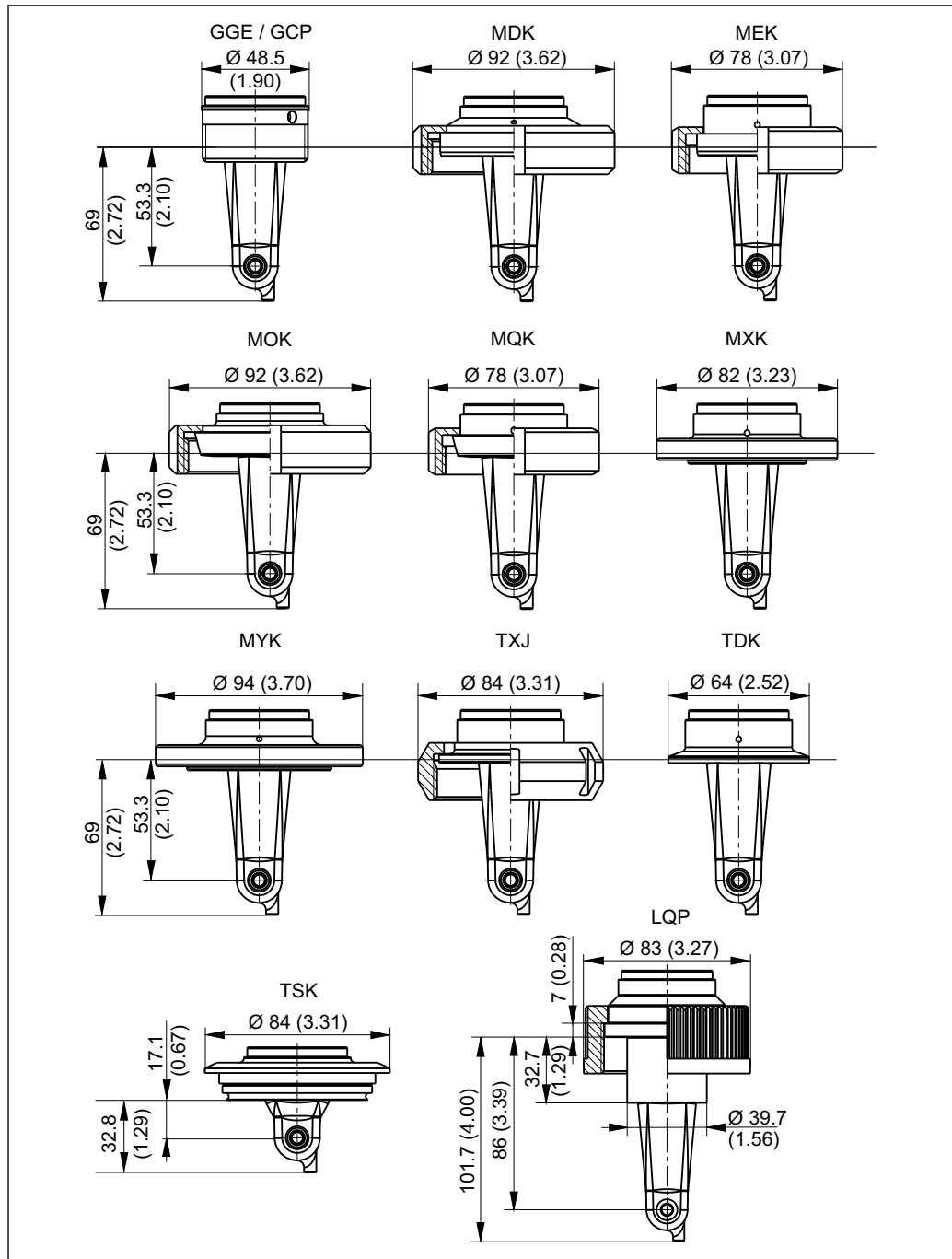

A0018955

9 Process connections, dimensions in mm (inch)

GGE	Thread G1½
GCP	Thread G1½ PVC
MDK	Aseptic DIN 11864-1-A DN 50
MEK	Aseptic DIN 11864-1-A DN 40
MOK	Dairy fitting DIN 11851 DN 50
MQK	Dairy fitting DIN 11851 DN 40
MXK	Dairy fitting DIN 11853 -2 DN 40
MYK	Dairy fitting DIN 11853 -2 DN 50
TXJ	SMS 2"
TDK	Tri-Clamp ISO 2852 2"
TSK	Varivent N DN 40 to 125
LQP	Coupling nut 2¼" PVC

<b>Weight</b>	Stainless steel housing:	up to 1.870 kg (4.12 lbs)
	Plastic housing:	up to 1.070 kg (2.36 lbs)

**Materials**

**In contact with medium**

Sensor:	PEEK (polyetheretherketone)
Process connection:	Stainless steel 1.4435 (AISI 316 L), PVC-U
Seal:	EPDM

**Not in contact with medium**

Stainless steel housing:	Stainless steel 1.4308 (ASTM CF-8, AISI 304)
Plastic housing:	PBT GF20
Seals:	EPDM
Window:	PC
Cable glands:	PA, TPE

## Operability

**Display and operating elements**

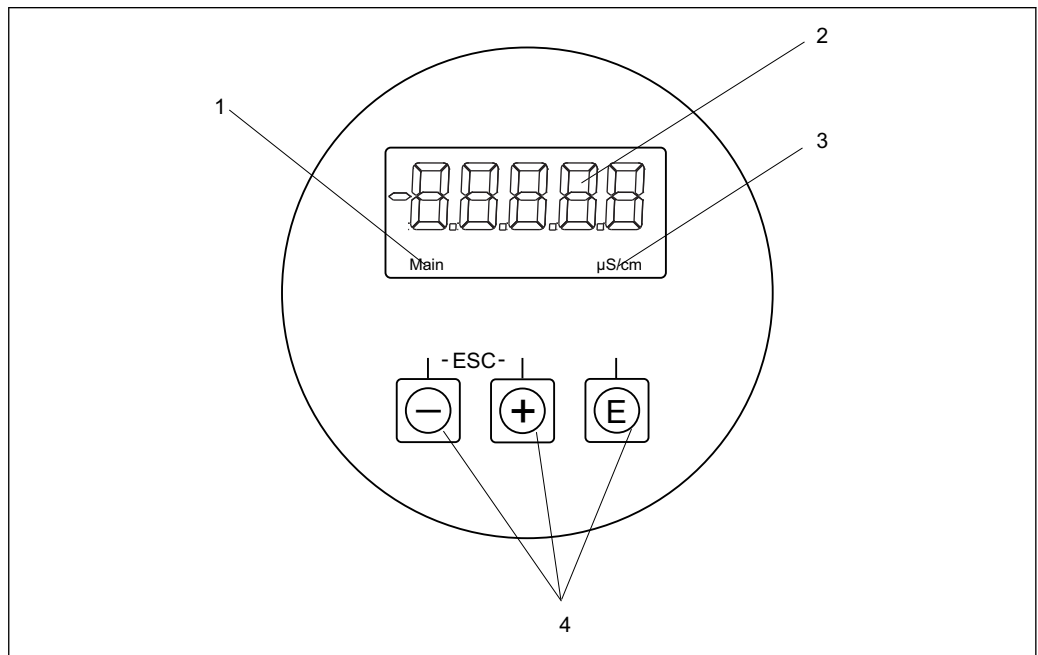

A0018963

10 Display and keys of the CLD18

- 1 Parameters
- 2 Measured value
- 3 Unit
- 4 Operating keys

The ASTN display (Advanced Super Twisted Nematic) is split into two sections. The segment section displays the measured value. The dot-matrix section displays the parameter and unit. The operating texts are displayed in English.

In the event of an error the device automatically alternates between displaying the error and the measured value.

## Certificates and approvals

<b>Hygiene</b>	<p><b>FDA</b></p> <p>All materials in contact with the product are FDA-listed materials (apart from the PVC process connections).</p> <p><b>EHEDG</b></p> <p>Certified cleanability according to EHEDG Type EL Class I.</p> <p> When using the sensor in hygienic applications, please note that the cleanability of the sensor also depends on the way the sensor is installed. To install the sensor in a pipe, use the appropriate and EHEDG-certified flow vessels for the particular process connection.</p> <p><b>3-A</b></p> <p>Certified according to 3-A Standard 74- ("3-A Sanitary Standards for Sensor and Sensor Fittings and Connections Used on Milk and Milk Products Equipment").</p> <p><b>EC Regulation No. 1935/2004</b></p> <p>The sensor meets the requirements of EC Regulation No. 1935/2004 on materials and articles intended to come into contact with food.</p>
<b>Pressure approval</b>	Canadian pressure approval for pipes according to ASME B31.3
<b>CE mark</b>	The product meets the requirements of the harmonized European standards. As such, it complies with the legal specifications of the EC directives. The manufacturer confirms successful testing of the product by affixing to it the <b>CE</b> mark.

## Ordering information

<b>Product page</b>	<a href="http://www.endress.com/CLD18">www.endress.com/CLD18</a>
<b>Product Configurator</b>	<p>On the product page there is a "Configuration" button to the right of the product image.</p> <ol style="list-style-type: none"> <li>1. Click this button. <ul style="list-style-type: none"> <li>↳ The Configurator opens in a separate window.</li> </ul> </li> <li>2. Select all the options to configure the device in line with your requirements. <ul style="list-style-type: none"> <li>↳ In this way, you receive a valid and complete order code for the device.</li> </ul> </li> <li>3. Export the order code as a PDF or Excel file. To do so, click the appropriate button on the right above the selection window.</li> </ol> <p> For many products you also have the option of downloading CAD or 2D drawings of the selected product version. To do so, click the "CAD" tab and select the desired file type using drop-down lists.</p>
<b>Scope of delivery</b>	<p>The delivery comprises:</p> <ul style="list-style-type: none"> <li>■ A Smartec CLD18 measuring system in the version ordered</li> <li>■ Operating Instructions BA01149C/07/EN</li> </ul>

## Accessories



The following are the most important accessories available at the time this documentation was issued. For accessories not listed here, please contact your service or sales office.

---

### Standard solutions

#### Conductivity calibration solutions CLY11

Precision solutions referenced to SRM (Standard Reference Material) by NIST for qualified calibration of conductivity measuring systems in accordance with ISO 9000

- CLY11-C, 1.406 mS/cm (reference temperature 25 °C (77 °F)), 500 ml (16.9 fl.oz)  
Order No. 50081904
- CLY11-D, 12.64 mS/cm (reference temperature 25 °C (77 °F)), 500 ml (16.9 fl.oz)  
Order No. 50081905
- CLY11-E, 107.00 mS/cm (reference temperature 25 °C (77 °F)), 500 ml (16.9 fl.oz)  
Order No. 50081906



Technical Information TI00162C

[www.addresses.endress.com](http://www.addresses.endress.com)

---