

Technical Information

EngyCal[®] RS33

Steam calculator

For recording and billing the steam mass and energy flow in applications with saturated steam or superheated steam



Transparent energy consumption helps you save on energy costs

Application

- Recording and billing energy quantities in steam applications

Typical applications are in:

- the food industry
- the chemical industry
- the pharmaceutical industry
- power plants
- building services and plant engineering and construction.

Your benefits

- Compensation of differential pressure flow measurement
- Fast commissioning thanks to easy operation in selectable language and plain-text display
- Remote readout via Ethernet and fieldbuses
- Calculation according to international steam tables
- Integrated data logging
- Tariff counter for requirements-specific metering
- Standard models are suitable for connecting and supplying all common flow transmitters, temperature sensors and pressure sensors
- Deficit counter for transparency in case of error or alarm
- Detailed data logging of current and counter values and of error messages, off-limit conditions and changes to operating parameters
- Industry-compliant compact housing for field or wall mounting, panel mounting or top-hat rail mounting
- Electronic alignment of the temperature sensor with the arithmetic unit (sensor-transmitter matching) enables high-accuracy temperature measurement

Function and system design

Measuring principle

The EngyCal® RS33 steam calculator is used for recording the steam mass and energy flow in systems with saturated steam or superheated steam. The calculation is based on the measured process values volume flow, temperature and/or pressure. Depending on the installation position of the measuring devices the heat quantity can be determined using different calculation methods. This can be performed using standard heat quantity calculations, or using steam delta heat measurement. If steam delta heat measurement is used, attention must be paid to the installation position of the measuring devices.

The measured and calculated values can be output via ethernet, fieldbuses or as an analog signal. The meters are easy to install and read. Thanks to its verified long-term stability and high-precision measurements, the device helps optimize processes and control costs in the process. Comprehensive data analysis options in the Field Data Manager software MS20 (see accessories) identify potential areas for cost reduction.

Measuring system

Development of different applications such as heat quantity or delta heat with the steam calculator

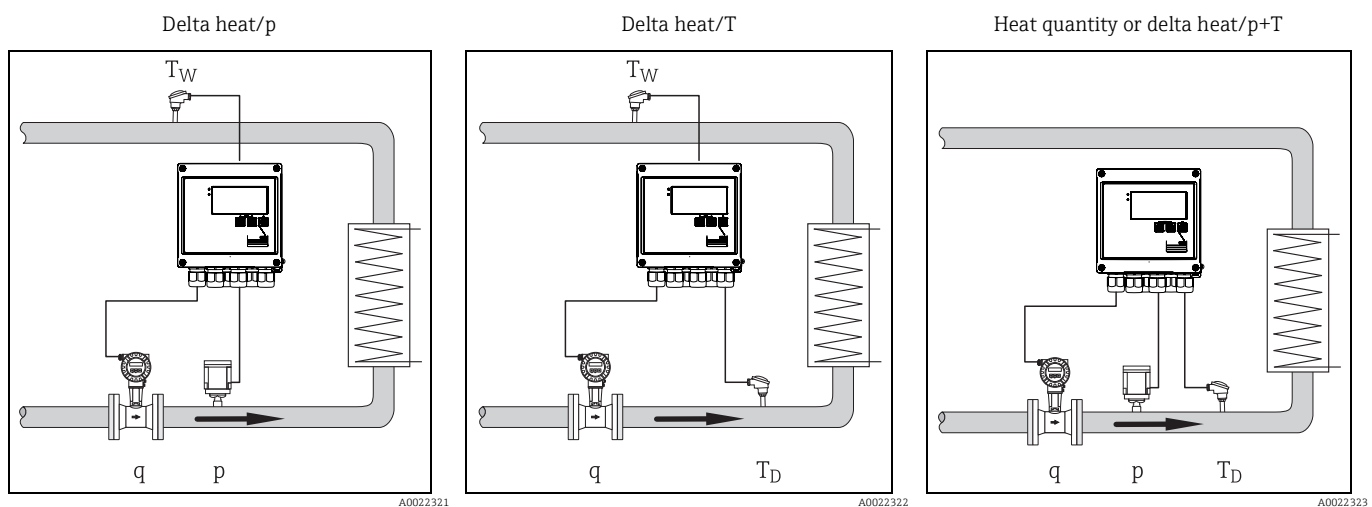

Functions

Energy calculation

EngyCal® RS33 uses the IAPWS IF97 standard to calculate the mass flow and energy flow of steam. Here, the density and enthalpy of steam is calculated from the input variables pressure and temperature.

Calculated values:

- Power
- Volume
- Mass
- Density
- Enthalpy
- DP flow compensation

Counters:

- Volume
- Mass
- Energy
- Deficit

Optional:

Tariff1, tariff2

Temperature-sensor matching in the computer

The temperature sensor is adapted internally in the EngyCal® RS33 by storing the sensor characteristic curves via Callendar-van-Dusen coefficients. The Callendar-van-Dusen coefficients are determined by calibrating the temperature sensor.

Compensation of differential pressure flow measurement

The flow calculation according to the differential pressure method is a special form of flow measurement. Volume or mass flow values measured according to the DP method require a specific correction. The iterative solution of the calculation equations listed there allow the best possible accuracy (ca. 0.6 – 1 %) to be attained for DP flow measurements.

Compensation of flow measurement for throttle methods (orifice plate, nozzle).

The measurement (orifice plate, nozzle, Venturi pipe) is carried out according to ISO5167. Flow measurements according to the dynamic pressure method are determined according to the relationship between the differential pressure and flow.

Data logging and logbook

Event logbook:

The EngyCal RS33® steam calculator has a logbook for measured values and a logbook for events.

In the event logbook, all parameter changes, off-limit conditions, alarms and other events are documented with timestamp such that they are tamper-proof. At minimum, the last 1600 events are stored in non-volatile memory.

The data logging allows process values and calculated values, as well as counters, to be stored in freely definable intervals. Predefined analyses (Day, Month, Year, Billing dates) support the transparency of the process and ensure a quick overview of all consumption values.

All entries into the event logbook and the logged data can be read out automatically via the visualization software (Field Data Manager Software) and backed up in an SQL database so that it is tamper-proof.

For fast and easy-to-understand analysis in case of service, an internal diagnostic memory with occurred error messages is also available.

Analysis	No. of analyses
Interval (1min)	Approx. 700
Day	260 days
Month/year/billing date	17 years
Events	At least 1600 (depending on the length of the message text)

Wet steam alarm

If steam condenses, reliable and accurate calculation of the energy quantity is no longer guaranteed. The wet steam alarm indicates the condensation of steam. The aggregate state can be determined on the basis of pressure and temperature. This is required in order to trigger the wet steam alarm.

Limit value monitoring

EngyCal® RS33 has 3 limits that can be assigned as desired to the following measured and calculated values:

Volume flow, steam temperature, pressure, mass flow, power (heat flow), density, enthalpy, operating volume, heat and tariff 1, tariff 2

In case of violation of the defined limits, an entry is made into the event logbook. In addition, relays can be switched and the off-limit condition can be indicated on the display. Limits are also available via the integrated web server.

Fault mode / deficit counter

EngyCal® RS33 has a definable fault mode (no further calculation or calculation with error value).

For the case of further calculation with an error value, the total calculated energy during the error condition (e.g. cable open circuit or wet steam alarm) is counted on a deficit counter.

In this case, the output continues to supply the calculated energy value. If values are communicated via buses, these are given the value "invalid". Optionally, an alarm relay can be switched.

Tariff counters (optional)

The tariff counters enable analysis and recording of the energy on an additional counter.

Two types of tariff counter are available: A defined tariff can be activated by an event or via the digital inputs. If the defined event occurs, the calculated energy is counted at this tariff.

Tariff counters enable, for example, invoicing on specific billing dates (due date invoicing), requirements-based billing (daytime/nighttime tariff) and analysis of counters when reaching set points, e.g. power-dependent.

Various tariff models are available for selection in the device, e.g. Energy; Power; Mass flow; Wet steam; Time.

The standard counters continue running at the same time, e.g. they are not affected by the activation of the tariff counters.

Real time clock (RTC)

The device has a real time clock that can be synchronized via a free digital input or using the Field Data Manager software MS20.

The real time clock continues running even in case of a power failure, the device documents power on and off; the clock switches automatically or (optionally) manually from daylight saving to standard time.

Display

To display measured values, counters and calculated values, 6 groups are available. Each group can be assigned up to 3 values or meter readings as desired.

Analyzing the stored data - Field Data Management software MS20

The Field Data Manager Software allows the stored measured values, alarms and events, and the device configuration to be read out from the device (automatically) so that they are tamper-proof and stored securely in an SQL database. The software offers centralized data management with a variety of visualization functions. Using an integrated system service, analyses and reports can be created, printed and stored fully automatically. Security is provided by the FDA-compliant audit trail of the software and the extensive user management. Simultaneous access and analysis of data from various workstations or users is supported (client-server architecture).

Input

Current/pulse input

This input can be used either as a current input for 0/4 to 20 mA signals or as a pulse input or frequency input.

The input is galvanically isolated (500 V testing voltage towards all other inputs and outputs).

Cycle time

The cycle time is 250 ms or 500 ms respectively when using one or two RTD inputs.

Reaction time

In the case of analog signals, the reaction time is the time between the change at the input and the time when the output signal is equivalent to 90% of the full scale value. The reaction time is lengthened by 250 ms if an RTD with 3-wire measurement is connected.

Input	Output	Reaction time [ms]
Current	Current	≤ 600
Current	Relay/digital output	≤ 600
RTD	Current/ relay/digital output	≤ 600
Cable open circuit detection	Current/ relay/digital output	≤ 600
Cable open circuit detection, RTD	Current/ relay/digital output	≤ 1100
Pulse input	Pulse output	≤ 600

Current input

Measuring range:	0/4 to 20 mA + 10 % over range
Accuracy:	0.1 % of full scale value
Temperature drift:	0.01 %/K (0.0056 %/°F) of the full scale value
Loading capacity:	Max. 50 mA, max. 2.5 V
Input impedance (load):	50 Ω
HART® signals	Not affected
A/D converter resolution:	20 bit

Pulse/frequency input

The pulse/frequency input can be configured for different frequency ranges:

- Pulses and frequencies up to 12.5 kHz
- Pulses and frequencies up to 25 Hz (filters out bounce contacts, max. bounce time: 5 ms)

Minimum pulse width:	
Range up to 12.5 kHz	40 μ s
Range up to 25 Hz	20 ms
Maximum permissible contact bounce time:	
Range up to 25 Hz	5 ms
Pulse input for active voltage pulses and contact sensors as per EN 1434-2, Class IB and IC:	
Non-conductive state	≤ 1 V
Conductive state	≥ 2 V
No-load supply voltage:	3 to 6 V
Current limiting resistance in the power supply (pull-up at input):	50 k Ω to 2 M Ω
Maximum permissible input voltage:	30 V (for active voltage pulses)
Pulse input for contact sensors as per EN 1434-2, Class ID and IE:	
Low-level	≤ 1.2 mA
High-level	≥ 2.1 mA
No-load supply voltage:	7 to 9 V
Current limiting resistance in the power supply (pull-up at input):	562 Ω to 1 k Ω
Not suitable for active input voltages.	
Current/pulse input:	
Low-level	≤ 8 mA
High-level	≥ 13 mA
Loading capacity:	Max. 50 mA, max. 2.5 V
Input impedance (load):	50 Ω
Accuracy during frequency measurement:	
Basic accuracy:	0.01 % of measured value
Temperature drift:	0.01 % of measured value over entire temperature range

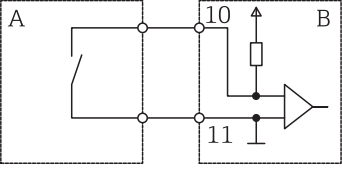
Pulse output of the flow sensor	RS33 setting	Electrical connection	Remark
Mechanical contact	Pulse ID/IE up to 25 Hz	 <p>A0015354</p> <p>A Sensor B RS33</p>	<p>"Pulse IB/IC+U" up to 25 Hz can also be used. The current through the contact is lower then (approx. 0.05 mA instead of 9 mA). Advantage: less load; disadvantage: lower interference resistance.</p>

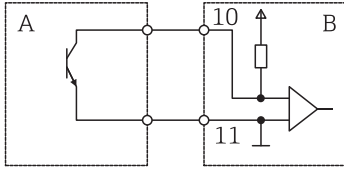
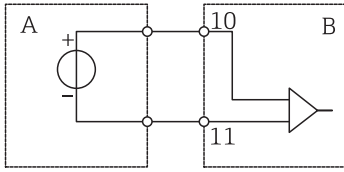
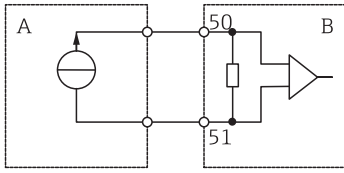
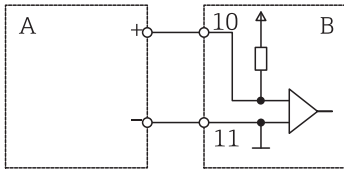
Pulse output of the flow sensor	RS33 setting	Electrical connection	Remark
Open Collector (NPN)	Pulse ID/IE up to 25 Hz or up to 12.5 kHz	 <p style="text-align: right; font-size: small;">A0015355</p> <p>A Sensor B RS33</p>	<p>"Pulse IB/IC+U" can also be used. The current through the contact is lower then (approx. 0.05 mA instead of 9 mA). Advantage: less load; disadvantage: lower interference resistance.</p>
Active voltage	Pulse IB/IC+U	 <p style="text-align: right; font-size: small;">A0015356</p> <p>A Sensor B RS33</p>	<p>The switching threshold is between 1 V and 2 V</p>
Active current	Pulse I	 <p style="text-align: right; font-size: small;">A0015357</p> <p>A Sensor B RS33</p>	<p>The switching threshold is between 8 mA and 13 mA</p>
Namur sensor (as per EN60947-5-6)	Pulse ID/IE up to 25 Hz or up to 12.5 kHz	 <p style="text-align: right; font-size: small;">A0015359</p> <p>A Sensor B RS33</p>	<p>No monitoring for short circuit is carried out.</p>

2 x current/RTD input

These inputs can be used either as current inputs (0/4 to 20 mA) or as resistance temperature detector (RTD) inputs. Here, one input is provided for the temperature signal, the other for the pressure signal. The two inputs are galvanically connected but galvanically isolated from the other inputs and outputs (testing voltage: 500 V).

Current input

Measuring range:	0/4 to 20 mA + 10 % over range
Accuracy:	0.1 % of full scale value
Temperature drift:	0.01 %/K (0.0056 %/°F) of the full scale value
Loading capacity:	Max. 50 mA, max. 2.5 V
Input impedance (load):	50 Ω
A/D converter resolution:	24 bit
HART® signals are not affected.	

RTD input

Pt100, Pt500 and Pt1000 resistance temperature detectors can be connected to this input.

Measuring ranges:	
Pt100_exact:	-200 to 300 °C (-328 to 572 °F)
Pt100_wide:	-200 to 600 °C (-328 to 1112 °F)
Pt500:	-200 to 300 °C (-328 to 572 °F)
Pt1000:	-200 to 300 °C (-328 to 572 °F)
Connection method:	2-, 3- or 4-wire connection
Accuracy:	4-wire: 0.06% of measuring range 3-wire: 0.06% of the measuring range + 0.8 K (1.44 °F)
Temperature drift:	0.01 %/K (0.0056 %/°F) of the measuring range
Characteristic curves:	DIN EN 60751:2008 IPTS-90
Max. cable resistance:	40 Ω
Cable open circuit detection:	Outside the measuring range

Digital inputs

Two digital inputs are available for switching the following functions.

Digital input 1	Digital input 2
Activate tariff counter 1 Time synchronization Lock device (Block set up)	Activate tariff counter 2 Time synchronization Lock device (Block set up)

Input level:

To IEC 61131-2 type 3:

Logical "0" (corresponds to -3 to +5 V), activation with logical "1" (corresponds to +11 to +30 V)

Input current:

Max. 3.2 mA

Input voltage:

Max. 30 V (steady-state, without destroying the input)

Output

Current/pulse output (option)

This output can be used either as a 0/4 to 20 mA current output or as a voltage pulse output. The output is galvanically isolated (500 V testing voltage towards all other inputs and outputs).

Current output

Output range:	0/4 to 20 mA + 10 % over range
Load:	0 to 600 Ω (as per IEC 61131-2)
Accuracy:	0.1 % of full scale value
Temperature drift:	0.01 %/K (0.0056 %/°F) of the full scale value
Inductive load:	Max. 10 mH
Capacitance load:	Max. 10 μ F
Ripple:	Max. 12 mVpp on 600 Ω for frequencies < 50 kHz
D/A converter resolution:	14 bit

Pulse output

Frequency:	Max. 12.5 kHz
Pulse width:	Min. 40 μ s
Voltage level:	Low: 0 to 2 V High: 15 to 20 V
Maximum output current:	22 mA
Short-circuit proof	

2 x relay output

The relays are designed as NO contacts. The output is galvanically isolated (1500 V testing voltage towards all other inputs and outputs).

Max. relay switching capacity:	AC: 250 V, 3 A DC: 30 V, 3 A
Minimum contact load:	10 V, 1 mA
Min. switching cycles:	>10 ⁵

2 x digital output, open collector (option)

The two digital inputs are galvanically isolated from one another and from all the other inputs and outputs (testing voltage: 500 V). The digital outputs can be used as status or pulse outputs.

Frequency:	Max. 1 kHz
Pulse width:	Min. 500 μ s
Current:	Max. 120 mA
Voltage:	Max. 30 V
Voltage drop:	Max. 2 V in conductive state
Maximum load resistance:	10 k Ω For higher values, the switching edges are flattened.

**Auxiliary voltage output
(transmitter power supply)**

The auxiliary voltage output can be used to power the transmitter or control the digital inputs. The auxiliary voltage is short-circuit proof and galvanically isolated (500 V testing voltage towards all other inputs and outputs).

Output voltage:	24 V DC ±15% (not stabilized)
Output current:	Max. 70 mA
HART® signals are not affected.	

Terminal assignment

Electrical connection (circuit diagrams)

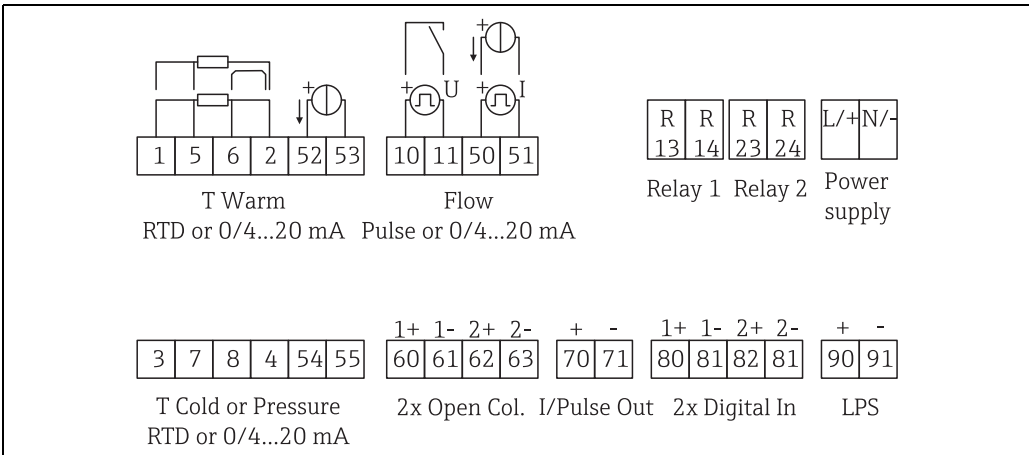

Terminal assignment of the EngyCal® RS33.

A0022341

Supply voltage

- Low-voltage power unit: 100 to 230 V AC (-15% / +10%) 50/60 Hz
- Extra-low voltage power unit:
 24 V DC (-50% / +75%)
 24 V AC (±50%) 50/60 Hz

An overload protection unit (rated current ≤ 10 A) is required for the power cable.

Power consumption

15 VA

Communication interfaces

A USB interface (with CDI protocol), and optionally Ethernet, are used to configure the device and read out the values. ModBus and M-Bus are optionally available as communication interfaces. None of the interfaces has a modifying effect on the device in accordance with PTB Requirement PTB-A 50.1.

USB device

Connection:	Type B socket
Specification:	USB 2.0
Speed:	Full speed (max. 12 MBit/sec)
Max. cable length:	3 m (9.8 ft.)

Ethernet TCP/IP

The Ethernet interface is optional, and cannot be combined with other optional interfaces. It is galvanically isolated (testing voltage: 500 V). A standard patch cable (e.g. CAT5E) can be used to connect the Ethernet interface. A special cable gland is available for this purpose which allows users to guide pre-terminated cables through the housing. Via the Ethernet interface, the device can be connected to office equipment using a hub or a switch.

Standard:	10/100 Base-T/TX (IEEE 802.3)
Socket:	RJ-45
Max. cable length:	100 m (328 ft.)

Web server

When the device is connected via Ethernet, the display values can also be read out via the Internet using a web server.

Data can be read out via the web server in HTML or XML format.

RS485

Connection	3-pin plug-in terminal
Transmission protocol	RTU
Transmission rate	2400/4800/9600/19200/38400
Parity	Choose from None, Even, Odd

Modbus TCP

The Modbus TCP interface is optional, and cannot be ordered with other optional interfaces. It is used to connect the device to higher-order systems to transmit all measured values and process values. The Modbus TCP interface is physically identical to the Ethernet interface.

Modbus RTU

The Modbus RTU (RS-485) interface is optional, and cannot be ordered with other optional interfaces. It is galvanically isolated (testing voltage: 500 V) and used to connect the device to higher-order systems to transmit all measured values and process values. It is connected via a 3-pin plug-in terminal.

M-Bus

The M-Bus (Meter Bus) interface is optional, and cannot be ordered with other optional interfaces. It is galvanically isolated (testing voltage: 500 V) and used to connect the device to higher-order systems to transmit all measured values and process values. It is connected via a 3-pin plug-in terminal.

Performance characteristics

Reference operating conditions

- Power supply 230 V AC \pm 10%; 50 Hz \pm 0.5 Hz
- Warm-up time > 2 h
- Ambient temperature 25 °C \pm 5 K (77 \pm 9 °F)
- Humidity 39% \pm 10% RH

Arithmetic unit

Medium	Variable	Range
Steam	Temperature measuring range	0 to 800 °C (32 to 1472 °F)
	Pressure measuring range	0 to 1000 bar (0 to 14500 PSI)
	Measurement and calculation interval	500 ms

Calculation standard IAPWS IF97

Typical accuracy in steam mass and energy measurement of a complete steam measuring point: approx. 1.5 % (e.g. Cerabar S, TR 10, Prowirl 72, EngyCal® RS33)

Installation

Installation instructions

Mounting location

Wall/pipe mounting, panel or top-hat rail as per IEC 60715¹⁾

Orientation

The orientation is only determined by the legibility of the display.

1) According to UL approval panel or surface mountable only.

Environment

Ambient temperature range	-20 to +60 °C (-4 to +140 °F)
Storage temperature	-30 to +70 °C (-22 to 158 °F)
Climate class	As per IEC 60 654-1 Class B2, as per EN 1434 ambient class C
Humidity	Maximum relative humidity 80 % for temperatures up to 31 °C (87.8 °F), decreasing linearly to 50 % relative humidity at 40 °C (104 °F).
Electr. safety	As per IEC 61010-1, UL61010-1 and CAN C22.2 No 1010-1. <ul style="list-style-type: none">■ Protection class II■ Overvoltage category II■ Pollution degree 2■ Overload protection ≤ 10 A■ Operating altitude: up to 2000 m (6560 ft) above MSL
Degree of protection	<ul style="list-style-type: none">■ Panel mounting: IP65 front panel, IP20 rear panel (not evaluated by UL)■ Top-hat rail: IP20■ Field housing: IP66, NEMA4x (for cable gland with double seal insert: IP65) (not evaluated by UL)
Electromagnetic compatibility	As per EN 1434-4, EN 61326 and Namur NE21

Mechanical construction

Design, dimensions

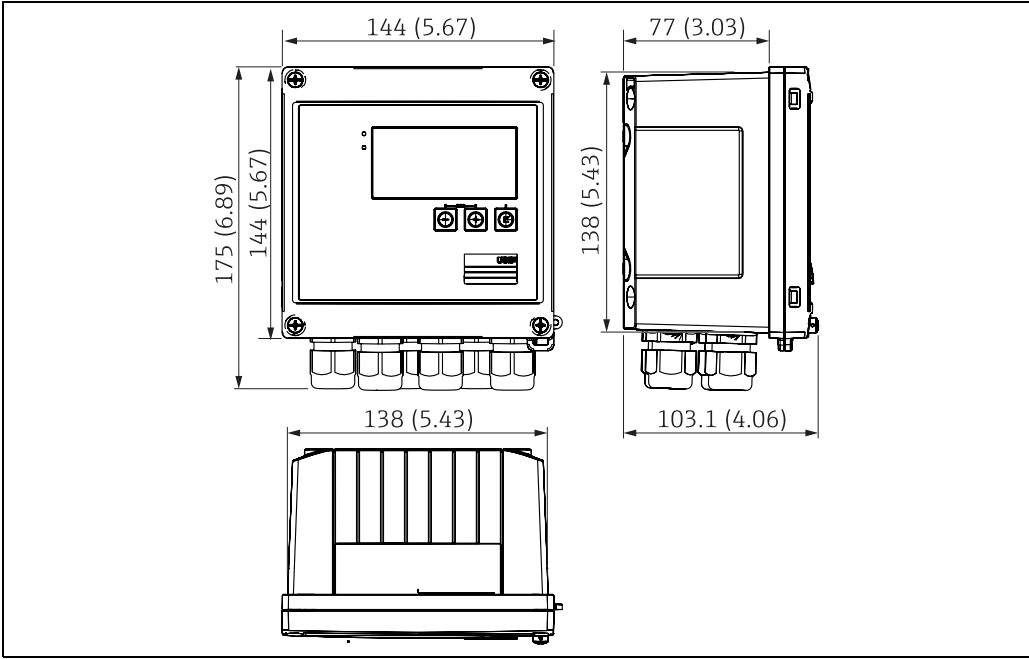

Dimensions in mm (in)

Weight	Approx. 700 g (1.5 lbs)
Material	Housing: fiber-glass reinforced plastic, Valox 553
Terminals	Spring terminals, 2.5 mm ² (14 AWG); auxiliary voltage with plug-in screw terminal (AWG30-12; torque 0.5-0.6 Nm).

Human interface

Display elements

- Display:
160 x 80 dot matrix LCD with white background, color switches to red in an alarm condition, active display area 70 x 34 mm
- LED status display:
Operation: 1 x green
Fault indication: 1 x red

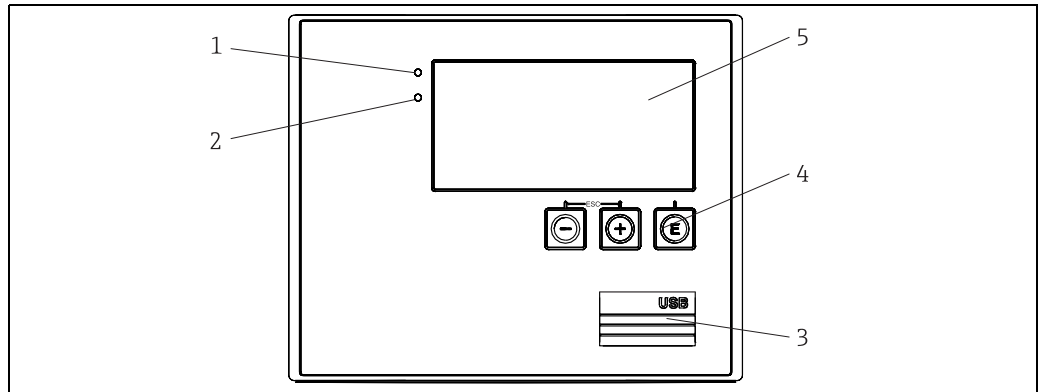

Display and operating elements

- | | |
|---|----------------------------------|
| 1 | LED green, "Operation" |
| 2 | LED red, "Fault indicator" |
| 3 | USB connection for configuration |
| 4 | Operating keys: -, +, E |
| 5 | 160x80 DOT matrix display |

A0013444

Local operation

3 keys, "-", "+", "E".

Configuration interface

USB interface, front-panel, optional Ethernet interface: configuration via PC with PC operating software.

Data logging

Real time clock

- Drift: 15 min per year
- Power reserve: 1 week

Software

- **Field Data Manager software MS20:** Visualization software and database for analyzing and evaluating the measuring data and calculated values, as well as tamper-proof data storage
- **FieldCare Device Setup:** The device can be programmed using the FieldCare PC software. FieldCare Device Setup is included in the scope of supply of the Commubox FXA291 or RXU10-G1 (see 'Accessories') or can be downloaded at no charge from www.products.endress.com/fieldcare.

Certificates and approvals

CE mark	The measuring system meets the legal requirements of the EU directives. Endress+Hauser confirms successful testing of the device by affixing to it the CE mark.
Other standards and guidelines	<ul style="list-style-type: none"> ■ IEC 60529: Degrees of protection provided by enclosures (IP code) ■ IEC 61010-1: 2001 cor 2003 Safety requirements for electrical equipment for measurement, control and laboratory use ■ IEC 61326 series: Electromagnetic compatibility (EMC requirements) ■ NAMUR NE21, NE43 Association for Standards for Control and Regulation in the Chemical Industry ■ IAWPS-IF 97 Internationally applicable and recognized calculation standard (since 1997) for steam and water. Issued by the International Association for the Properties of Water and Steam (IAPWS). ■ OIML R75 International construction and testing regulation for water energy managers by the Organisation Internationale de Métrologie Légale. ■ EN 1434 ■ EN ISO 5167 Measurement of fluid flow by means of pressure differential devices
CSA GP	CAN/CSA-C22.2 No. 61010-1, 2 nd Edition
UL approval	UL 61010-1, 2 nd Edition

Ordering information

Detailed ordering information is available from the following sources:

- In the Product Configurator on the Endress+Hauser website: www.endress.com → Select country → Instruments → Select device → Product page function: Configure this product
- From your Endress+Hauser Sales Center: www.endress.com/worldwide



Product Configurator - the tool for individual product configuration

- Up-to-the-minute configuration data
- Depending on the device: Direct input of information specific to measuring point, such as measuring range or operating language
- Automatic verification of exclusion criteria
- Automatic creation of the order code and its breakdown in PDF or Excel output format
- Ability to order directly in the Endress+Hauser Online Shop

Accessories

Software and communication

- USB cable and FieldCare Device Setup calibration software incl. DTM library
 - RXU10-G1
 - FXA291
- Visualization software and Field Data Manager MS20, SQL-based database software

Overvoltage protection

Overvoltage protection for sensors and devices:

- HAW569 surge arrester to screw into field housing, M20
- HAW562 surge arrester limiting high voltages on signal cables and components

Documentation

- Operating Instructions for 'EngyCal® RS33 Steam Calculator' (BA00294K/09)
- Technical Information for 'Surge Arrester HAW562' (TI01012K/09)
- Technical Information for 'Surge Arrester HAW569' (TI01013K/09)
- Brochure 'System components: Indicators with and without control unit for field and panel mounting, power supplies, barriers, transmitters, energy managers and surge arresters' (FA00016K/09)

www.addresses.endress.com
