

Technical Information

Micropilot FMR56, FMR57

Free space radar

Level measurement in bulk solids



Application

- Continuous, non-contact level measurement in powdery to granular bulk solids
- PP-cladded horn antenna (FMR56); horn or parabolic antenna (FMR57)
- Maximum measuring range: 70 m (230 ft)
- Temperature: -40 to +400 °C (-40 to 752 °F)
- Pressure: -1 to +16 bar (-14.5 to +232 psi)
- Accuracy: ± 3 mm
- International explosion protection certificates
- Linearity protocol (3-point, 5-point)

Your benefits

- Reliable measurement even for changing product and process conditions
- HistoROM data management for easy commissioning, maintenance and diagnostics
- Highest reliability due to Multi-Echo Tracking
- SIL2 according to IEC 61508, SIL3 in case of homogeneous or heterogeneous redundancy
- Seamless integration into control or asset management systems
- Intuitive user interface in national languages
- Easy proof test for SIL
- Heartbeat Technology™

Table of contents





Important document information	4	Process	49
Symbols	4	Process temperature, Process pressure	49
Function and system design	6	Dielectric constant	50
Measuring principle	6	Mechanical construction	51
Input	8	Dimensions	51
Measured variable	8	Weight	61
Measuring range	8	Materials: GT18 housing (stainless steel, corrosion-resistant)	62
Operating frequency	9	Materials: GT19 housing (plastic)	63
Transmitting power	9	Materials: GT20 housing (die-cast aluminum, powder-coated)	64
Output	10	Materials: Antenna and process connection	65
Output signal	10	Materials: Weather protection cover	68
Signal on alarm	11	Operability	69
Linearization	11	Operating concept	69
Galvanic isolation	11	Local operation	70
Protocol-specific data	11	Operation with remote display and operating module FHX50	70
Power supply	16	Remote operation	71
Terminal assignment	16	SupplyCare inventory management software	74
Device plug connectors	23	Certificates and approvals	77
Supply voltage	24	CE mark	77
Power consumption	26	RoHS	77
Current consumption	26	RCM-Tick marking	77
Power supply failure	27	Ex approval	77
Potential equalization	27	Dual seal according to ANSI/ISA 12.27.01	77
Terminals	27	Functional Safety	77
Cable entries	27	WHG	77
Cable specification	27	Pressure equipment with allowable pressure ≤ 200 bar (2 900 psi)	77
Overvoltage protection	28	Marine certificate	78
Performance characteristics	29	Radio standard EN302729-1/2	78
Reference operating conditions	29	Radio standard EN302372-1/2	79
Maximum measured error	29	FCC / Industry Canada	79
Measured value resolution	29	Japanese radio approval	79
Reaction time	30	CRN approval	79
Influence of ambient temperature	30	Track record	80
Installation	31	Test, Certificate	81
Installation conditions	31	Product documentation on paper	81
Measuring conditions	35	Other standards and guidelines	82
Installation in vessel (free space)	36	Ordering information	83
Vessels with heat insulation	42	Ordering information	83
Environment	43	3-point linearity protocol	84
Ambient temperature range	43	5-point linearity protocol	85
Ambient temperature limits	43	Customized parametrization	86
Storage temperature	47	Tagging (TAG)	86
Climate class	47	Services	86
Altitude according to IEC61010-1 Ed.3	47	Application Packages	87
Degree of protection	47	Heartbeat Diagnostics	87
Vibration resistance	47	Heartbeat Verification	88
Cleaning the antenna	47	Heartbeat Monitoring	89
Electromagnetic compatibility (EMC)	48		

Accessories	90
Device-specific accessories	90
Communication-specific accessories	96
Service-specific accessories	97
System components	97
Documentation	98
Standard documentation	98
Supplementary documentation	98
Safety Instructions (XA)	98
Registered trademarks	102
Patents	102





Important document information

Symbols









Safety symbols

Symbol	Meaning
	DANGER! This symbol alerts you to a dangerous situation. Failure to avoid this situation will result in serious or fatal injury.
	WARNING! This symbol alerts you to a dangerous situation. Failure to avoid this situation can result in serious or fatal injury.
	CAUTION! This symbol alerts you to a dangerous situation. Failure to avoid this situation can result in minor or medium injury.
	NOTE! This symbol contains information on procedures and other facts which do not result in personal injury.



Electrical symbols

Symbol	Meaning
	Direct current
	Alternating current
	Direct current and alternating current
	Ground connection A grounded terminal which, as far as the operator is concerned, is grounded via a grounding system.
	Protective Earth (PE) A terminal which must be connected to ground prior to establishing any other connections. The ground terminals are situated inside and outside the device: <ul style="list-style-type: none"> ▪ Inner ground terminal: Connects the protective earth to the mains supply. ▪ Outer ground terminal: Connects the device to the plant grounding system.



Symbols for certain types of information

Symbol	Meaning
	Permitted Procedures, processes or actions that are permitted.
	Preferred Procedures, processes or actions that are preferred.
	Forbidden Procedures, processes or actions that are forbidden.
	Tip Indicates additional information.
	Reference to documentation.
	Reference to page.
	Reference to graphic.
	Visual inspection.

Symbols in graphics

Symbol	Meaning
1, 2, 3 ...	Item numbers
	Series of steps
A, B, C, ...	Views
A-A, B-B, C-C, ...	Sections
	Hazardous area Indicates a hazardous area.
	Safe area (non-hazardous area) Indicates the non-hazardous area.

Symbols at the device

Symbol	Meaning
	Safety instructions Observe the safety instructions contained in the associated Operating Instructions.
	Temperature resistance of the connection cables Specifies the minimum value of the temperature resistance of the connection cables.

Function and system design

Measuring principle

The Micropilot is a "downward-looking" measuring system, operating based on the time-of-flight method (ToF). It measures the distance from the reference point (process connection) to the product surface. Radar impulses are emitted by an antenna, reflected off the product surface and received again by the radar system.

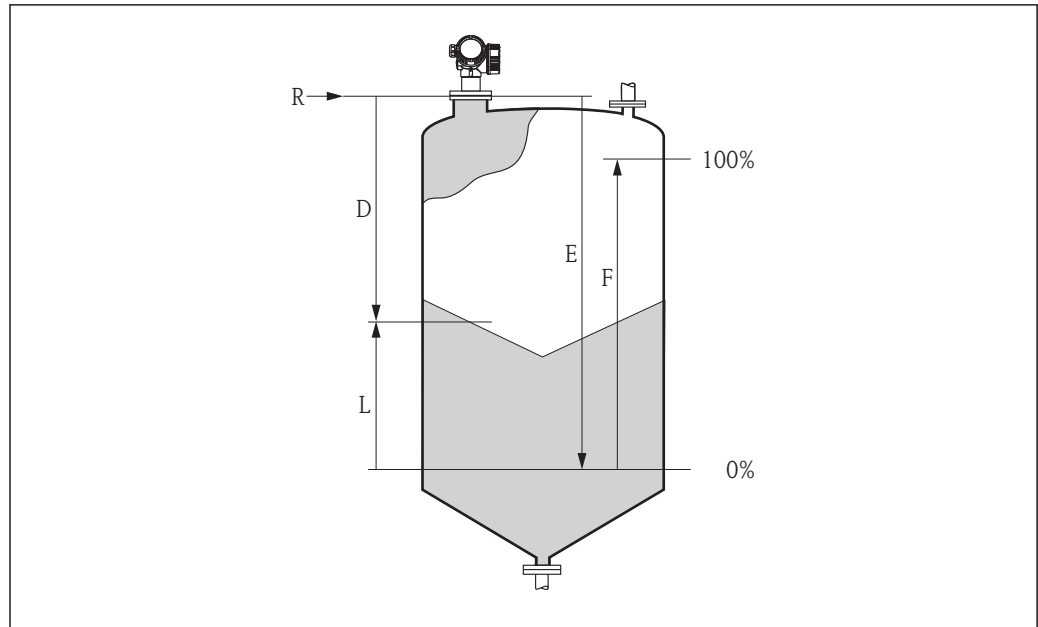

A0017872

1 Setup parameters of the Micropilot

- R* Reference point of the measurement (lower edge of the flange or threaded connection)
- E* Empty calibration (= zero)
- F* Full calibration (= span)
- D* Measured distance
- L* Level ($L = E - D$)

Input

The reflected radar impulses are received by the antenna and transmitted into the electronics. A microprocessor evaluates the signal and identifies the level echo caused by the reflection of the radar impulse at the product surface. The unambiguous signal identification is accomplished by the PulseMaster® eXact software together with the Multi-echo tracking algorithms, based on many years of experience with time-of-flight technology.

The distance D to the product surface is proportional to the time of flight t of the impulse:

$$D = c \cdot t / 2,$$

with c being the speed of light.

Based on the known empty distance E , the level L is calculated:

$$L = E - D$$

The reference point R of the measurement is located at the process connection. For details see the dimensional drawing:

- FMR56: → 52
- FMR57: → 56

The Micropilot is equipped with functions to suppress interference echoes. The user can activate these functions. Together with the multi-echo tracking algorithms they ensure that interference echoes (i.e. from edges and weld seams) are not interpreted as level echo.

Output

The Micropilot is commissioned by entering an empty distance "E" (=zero), a full distance "F" (=span) and application parameters which automatically adapt the instrument to the process conditions. For models with a current output, the factory adjustment for zero point "E" and span "F" is 4 mA and 20 mA. For digital outputs and the display module, the factory adjustment for zero point "E" and span "F" is 0 % and 100 %.

A linearization with max. 32 points, based on a table entered either manually or semi-automatically, can be activated locally or remotely. This function provides a measurement in engineering units and a linear output signal for spheres, horizontal cylindrical tanks and vessels with conical outlet.

Life cycle of the product

Engineering

- Universal measuring principle
- Measurement unaffected by medium properties
- Hardware and software developed according to SIL IEC 61508

Procurement

- Endress+Hauser being the world market leader in level measurement guarantees asset protection
- Worldwide support and service

Installation

- Special tools are not required
- Reverse polarity protection
- Modern, detachable terminals
- Main electronics protected by a separate connection compartment

Commissioning

- Fast, menu-guided commissioning in only a few steps on site or from the control room
- Plain text display in national languages reduces the risk of error or confusion
- Direct local access of all parameters
- Short instruction manual at the device

Operation

- Multi-echo tracking: Reliable measurement through self-learning echo-search algorithms taking into account the short-term and long-term history in order to check the found echoes for plausibility and to suppress interference echoes.
- Diagnostics in accordance with NAMUR NE107

Maintenance

- HistoROM: Data backup for instrument settings and measured values
- Exact instrument and process diagnosis to assist fast decisions with clear details concerning remedies
- Intuitive, menu-guided operating concept in national languages saves costs for training, maintenance and operation
- Cover of the electronics compartment can be opened in hazardous areas

Retirement

- Order code translation for subsequent models
- RoHS-conforming (Restriction of certain Hazardous Substances), unleaded soldering of electronic components
- Environmentally sound recycling concept

Input

Measured variable

The measured variable is the distance between the reference point and the product surface.

The level is calculated from this distance, taking into account the empty distance "E" entered by the user.

If required, the level can be converted into other variables (volume, mass) by means of a linearization (up to 32 points).

Measuring range

Maximum measuring range

Device	Maximum measuring range
FMR56	30 m (98 ft)
FMR57	70 m (230 ft)

Usable measuring range

The usable measuring range depends on the size of the antenna, the reflectivity of the medium, the mounting location and eventual interference reflections.

Reduction of the max. possible measuring range through:

- Media with poor reflection properties (= small DC). For examples refer to table below.
- Angle of repose
- Extremely loose surfaces of bulk solids, e.g. bulk solids with low bulk weight for pneumatic filling.
- Build-up, above all of moist products.

Media group	DC (ϵ_r)	Examples
A	1.6 to 1.9	<ul style="list-style-type: none"> ▪ Plastic granulate ▪ White lime, special cement ▪ Sugar
B	1.9 to 2.5	Portland cement, plaster
C	2.5 to 4	<ul style="list-style-type: none"> ▪ Grain, seeds ▪ Ground stones ▪ Sand
D	4 to 7	<ul style="list-style-type: none"> ▪ Naturally moist (ground) stones, ore ▪ Salt
E	> 7	<ul style="list-style-type: none"> ▪ Metallic powder ▪ Carbon black ▪ Coal

The respective lower group applies for very loose or loosened bulk solids.



For dielectric constants (DC values) of many media commonly used in various industries refer to:

- the Endress+Hauser DC manual (CP01076F)
- the Endress+Hauser "DC Values App" (available for Android and iOS)

Operating frequency

K-band (~ 26 GHz)

Up to 8 Micropilot transmitters can be installed in the same tank because the transmitter pulses are statistically coded.

Transmitting power

Distance	Average energy density in beam direction
1 m (3.3 ft)	< 64 nW/cm ²
5 m (16 ft)	< 2.5 nW/cm ²

Output

Output signal

HART

Signal coding	FSK ± 0.5 mA over current signal
Data transmission rate	1200 Bit/s
Galvanic isolation	Yes

PROFIBUS PA

Signal coding	Manchester Bus Powered (MBP)
Data transmission rate	31.25 kBit/s, voltage mode
Galvanic isolation	Yes

FOUNDATION Fieldbus

Signal coding	Manchester Bus Powered (MBP)
Data transmission rate	31.25 kBit/s, voltage mode
Galvanic isolation	Yes

Switch output

 For HART devices, the switch output is available as an option. See product structure, feature 20: "Power Supply, Output", option B: "2-wire; 4-20mA HART, switch output"

Devices with PROFIBUS PA and FOUNDATION Fieldbus always have a switch output.

Switch output	
Function	Open collector switching output
Switching behavior	Binary (conductive or non-conductive), switches when the programmable switch point is reached
Failure mode	non-conductive
Electrical connection values	$U = 16$ to $35 V_{DC}$, $I = 0$ to 40 mA
Internal resistance	$R_i < 880 \Omega$ The voltage drop at this internal resistance has to be taken into account on planning the configuration. For example, the resulting voltage at a connected relay must be sufficient to switch the relay.
Insulation voltage	floating, Insulation voltage $1\ 350 V_{DC}$ to power supply and $500 V_{AC}$ to ground
Switch point	freely programmable, separately for switch-on and switch-off point
Switching delay	freely programmable from 0 to 100 s, separately for switch-on and switch-off point
Number of switching cycles	corresponds to the measuring cycle
Signal source device variables	<ul style="list-style-type: none"> ▪ Level linearized ▪ Distance ▪ Terminal voltage ▪ Electronic temperature ▪ Relative echo amplitude ▪ Diagnostic values, Advanced diagnostics
Number of switching cycles	unlimited

Signal on alarm Depending on the interface, failure information is displayed as follows:

- Current output (for HART devices)
 - Failsafe mode selectable (in accordance with NAMUR Recommendation NE 43):
 - Minimum alarm: 3.6 mA
 - Maximum alarm (= factory setting): 22 mA
 - Failsafe mode with user-selectable value: 3.59 to 22.5 mA
- Local display
 - Status signal (in accordance with NAMUR Recommendation NE 107)
 - Plain text display
- Operating tool via digital communication (HART, PROFIBUS PA, FOUNDATION Fieldbus) or service interface (CDI)
 - Status signal (in accordance with NAMUR Recommendation NE 107)
 - Plain text display

Linearization The linearization function of the device allows the conversion of the measured value into any unit of length or volume. Linearization tables for calculating the volume in cylindrical tanks are pre-programmed. Other linearization tables of up to 32 value pairs can be entered manually or semi-automatically.

Galvanic isolation All circuits for the outputs are galvanically isolated from each other.

Protocol-specific data

HART

Manufacturer ID	17 (0x11)
Device type ID	0x1128
HART specification	7.0
Device description files (DTM, DD)	Information and files under: <ul style="list-style-type: none"> ■ www.endress.com ■ www.fieldcommgroup.org
HART load	min. 250 Ω
HART device variables	<p>The measured values can be freely assigned to the device variables.</p> <p>Measured values for PV (primary variable)</p> <ul style="list-style-type: none"> ■ Level linearized ■ Distance ■ Electronic temperature ■ Relative echo amplitude ■ Area of incoupling ■ Analog output adv. diagnostics 1 ■ Analog output adv. diagnostics 2 <p>Measured values for SV, TV, FV (second, third and fourth variable)</p> <ul style="list-style-type: none"> ■ Level linearized ■ Distance ■ Electronic temperature ■ Terminal voltage ■ Relative echo amplitude ■ Absolute echo amplitude ■ Area of incoupling ■ Analog output adv. diagnostics 1 ■ Analog output adv. diagnostics 2
Supported functions	<ul style="list-style-type: none"> ■ Burst mode ■ Additional transmitter status

Wireless HART data

Minimum start-up voltage	16 V
Start-up current	3.6 mA
Start-up time	65 s
Minimum operating voltage	14.0 V

Multidrop current	4.0 mA
Set-up time	15 s

PROFIBUS PA

Manufacturer ID	17 (0x11)
Ident number	0x1559
Profile version	3.02
GSD file	Information and files under:
GSD file version	<ul style="list-style-type: none"> ▪ www.endress.com ▪ www.profibus.org
Output values	<p>Analog Input:</p> <ul style="list-style-type: none"> ▪ Level linearized ▪ Distance ▪ Terminal voltage ▪ Electronic temperature ▪ Absolute echo amplitude ▪ Relative echo amplitude ▪ Analog output adv. diagnostics 1 ▪ Analog output adv. diagnostics 2 <p>Digital Input:</p> <ul style="list-style-type: none"> ▪ Digital output AD 1 ▪ Digital output AD 2 ▪ Switch output
Input values	<p>Analog Output:</p> <ul style="list-style-type: none"> ▪ Analog value from PLC (for sensor block external pressure to compensate gas phase effects) ▪ Analog value from PLC to be indicated on the display <p>Digital Output:</p> <ul style="list-style-type: none"> ▪ Extended diagnostic block ▪ Level limiter ▪ Sensor block measurement on ▪ Sensor block save history on ▪ Status output
Supported functions	<ul style="list-style-type: none"> ▪ Identification & Maintenance Einfachste Geräteidentifizierung seitens des Leitsystems und des Typenschildes ▪ Automatic Ident Number Adoption GSD compatibility mode with respect to the preceding product Micropilot M FMR2xx ▪ Physical Layer Diagnostics Installation check of the PROFIBUS segment and the Micropilot FMR5x via the terminal voltage and telegram surveillance. ▪ PROFIBUS Up-/Download Up to 10 times faster writing and reading of parameters via PROFIBUS up-/download ▪ Condensed Status Simple and self-explanatory diagnostic information by categorization of occurring diagnostic messages.

FOUNDATION Fieldbus

Manufacturer ID	0x452B48
Device type	0x1028
Device Revision	0x01
DD Revision	Information and files can be found:
CFF Revision	<ul style="list-style-type: none"> ▪ www.endress.com ▪ www.fieldcommgroup.org
Device Tester Version (ITK Version)	6.0.1
ITK Test Campaign Number	IT085300
Link Master (LAS) capable	yes

Link Master / Basic Device selectable	yes; default: Basic Device
Node address	Default: 247 (0xF7)
Features supported	Following methods are supported: <ul style="list-style-type: none"> ▪ Restart ▪ ENP Restart ▪ Setup ▪ Linearization ▪ Self Check
Virtual Communication Relationships (VCRs)	
Number of VCRs	44
Number of Link Objects in VFD	50
Permanent entries	1
Client VCRs	0
Server VCRs	10
Source VCRs	43
Sink VCRs	0
Subscriber VCRs	43
Publisher VCRs	43
Device Link Capabilities	
Slot time	4
Min. inter PDU delay	8
Max. response delay	20

Transducer Blocks

Block	Content	Output values
Setup Transducer Block	Contains all parameters for a standard commissioning procedure	<ul style="list-style-type: none"> ▪ Level or volume ¹⁾ (Channel 1) ▪ Distance (Channel 2)
Advanced Setup Transducer Block	Contains all parameters for a more detailed configuration of the device	no output values
Display Transducer Block	Contains all parameters for the configuration of the display module	no output values
Diagnostic Transducer Block	Contains diagnostic information	no output values
Advanced Diagnostic Transducer Block	Contains parameters for the Advanced Diagnostic	no output values
Expert Configuration Transducer Block	Contains parameters which require detailed knowledge of the functionalities of the device	no output values
Expert Information Transducer Block	Contains information about the state of the device	no output values
Service Sensor Transducer Block	Contains parameters which can only be operated by Endress+Hauser service personnel	no output values
Service Information Transducer Block	Contains information on the state of device which is relevant for service operations	no output values
Data Transfer Transducer Block	Contains parameters which allow to backup the device configuration in the display module and to restore it into the device. Access to these parameters is restricted to the Endress+Hauser service.	no output values

1) depending on the configuration of the block

Function Blocks

Block	Content	Number of permanent blocks	Number of instantiable blocks	Execution time	Functionality
Resource Block	The Resource Block contains all the data that uniquely identifies the field device. It is an electronic version of a nameplate of the device.	1	0	-	enhanced
Analog Input Block	The AI block takes the manufacturer's input data, selected by channel number, and makes it available to other function blocks at its output.	2	3	25 ms	enhanced
Discrete Input Block	The DI block takes a discrete input value (e.g. indication of an level limit), and makes it available to other function blocks at its output.	1	2	20 ms	standard
Mutiple Analog Output Block	This block is used to transfer analog data from the bus into the device	1	0	20 ms	standard
Mutiple Discrete Output Block	This block is used to transfer discrete data from the bus to the device.	1	0	20 ms	standard
PID Block	The PID block serves as proportional-integralderivative controller and is used almost universally to do closed-loop-control in the field including cascade and feedforward.	1	1	25 ms	standard
Arithmetic Block	This block is designed to permit simple use of popular measurement math functions. The user does not have to know how to write equations. The math algorithm is selected by name, chosen by the user for the function to be done.	1	1	25 ms	standard
Signal Characterizer Block	The signal characterizer block has two sections, each with an output that is a non-linear function of the respective input. The non-linear function is determined by a single look-up table with 21 arbitrary x-y pairs.	1	1	25 ms	standard
Input Selector Block	The input selector block provides selection of up to four inputs and generates an output based on the configured action. This block normally receives its inputs from AI blocks. The block performs maximum, minimum, middle, average and 'first good' signal selection.	1	1	25 ms	standard

Block	Content	Number of permanent blocks	Number of instantiable blocks	Execution time	Functionality
Integrator Block	The Integrator Function Block integrates a variable as a function of the time or accumulates the counts from a Pulse Input block. The block may be used as a totalizer that counts up until reset or as a batch totalizer that has a setpoint, where the integrated or accumulated value is compared to pre-trip and trip settings, generating discrete signals when these settings are reached.	1	1	25 ms	standard
Analog Alarm Block		1	1	25 ms	standard

 Up to 20 blocks can be instantiated in the device altogether, including the blocks already instantiated on delivery.

Power supply

Terminal assignment

2-wire: 4-20mA HART

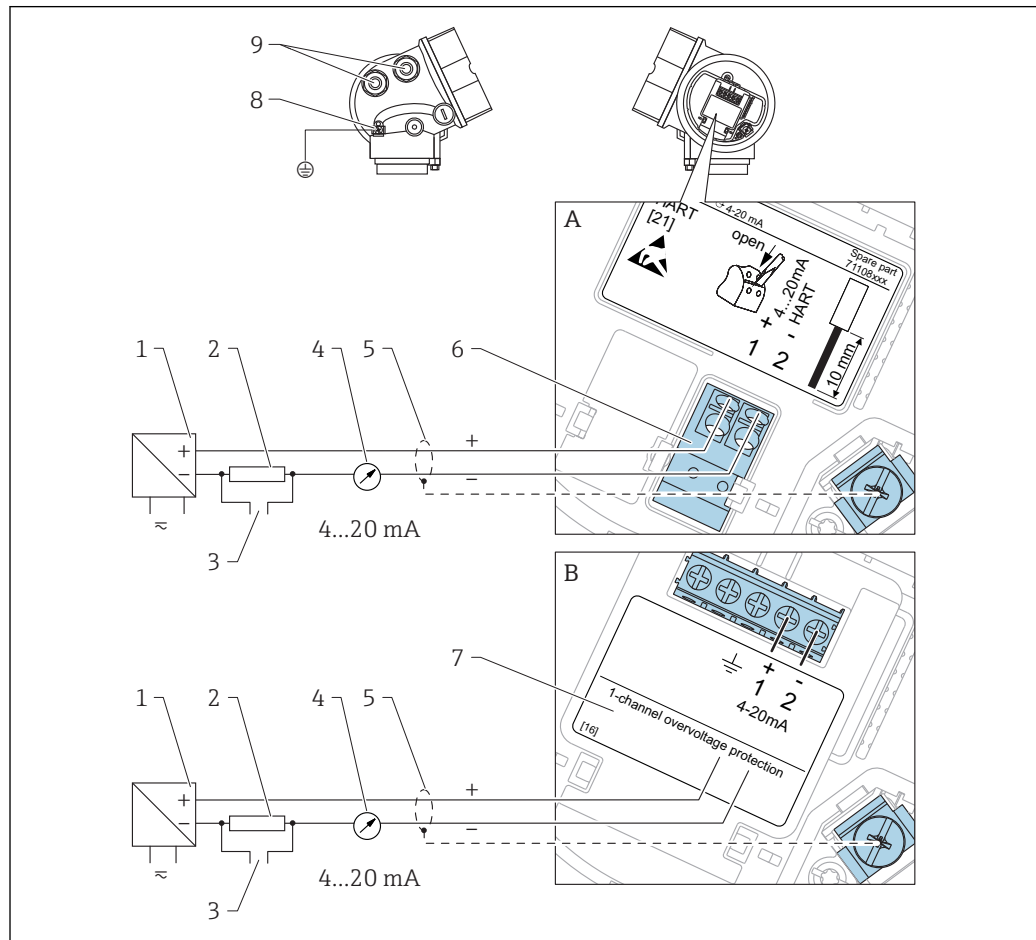

2 Terminal assignment 2-wire; 4-20mA HART

A Without integrated overvoltage protection

B With integrated overvoltage protection

1 Active barrier with power supply (e.g. RN221N): Observe terminal voltage

2 HART communication resistor ($\geq 250 \Omega$): Observe maximum load

3 Connection for Commubox FXA195 or FieldXpert SFX350/SFX370 (via VIATOR Bluetooth modem)

4 Analog display device: Observe maximum load

5 Cable screen; observe cable specification

6 4-20mA HART (passive): Terminals 1 and 2

7 Overvoltage protection module

8 Terminal for potential equalization line

9 Cable entry

2-wire: 4-20mA HART, switch output

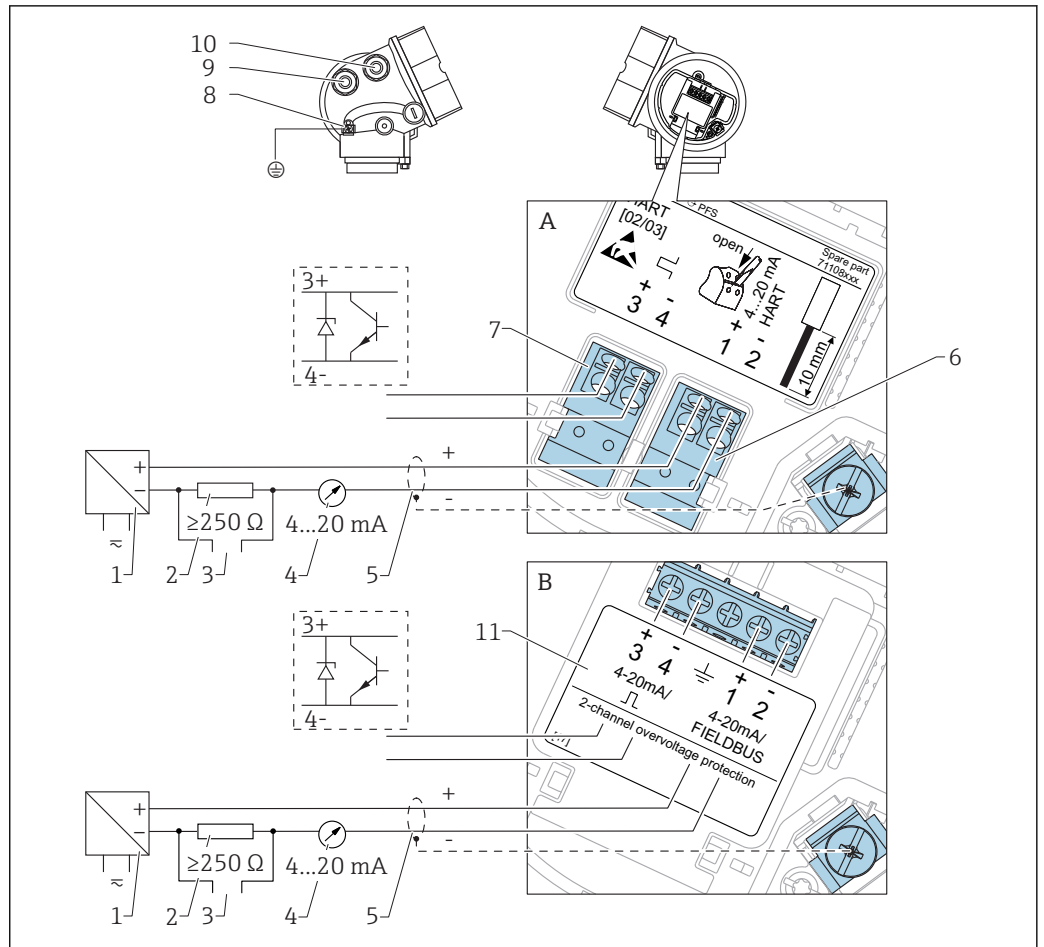

A0013759

3 Terminal assignment 2-wire; 4-20mA HART, switch output

A Without integrated overvoltage protection

B With integrated overvoltage protection

1 Active barrier with power supply (e.g. RN221N): Observe terminal voltage

2 HART communication resistor ($\geq 250 \Omega$): Observe maximum load

3 Connection for Commubox FXA195 or FieldXpert SFX350/SFX370 (via VIATOR Bluetooth modem)

4 Analog display device: Observe maximum load

5 Cable screen; observe cable specification

6 4-20mA HART (passive): Terminals 1 and 2

7 Switch output (open collector): Terminals 3 and 4

8 Terminal for potential equalization line

9 Cable entry for 4-20mA HART line

10 Cable entry for switch output line

11 Overvoltage protection module

2-wire: 4-20mA HART, 4-20mA

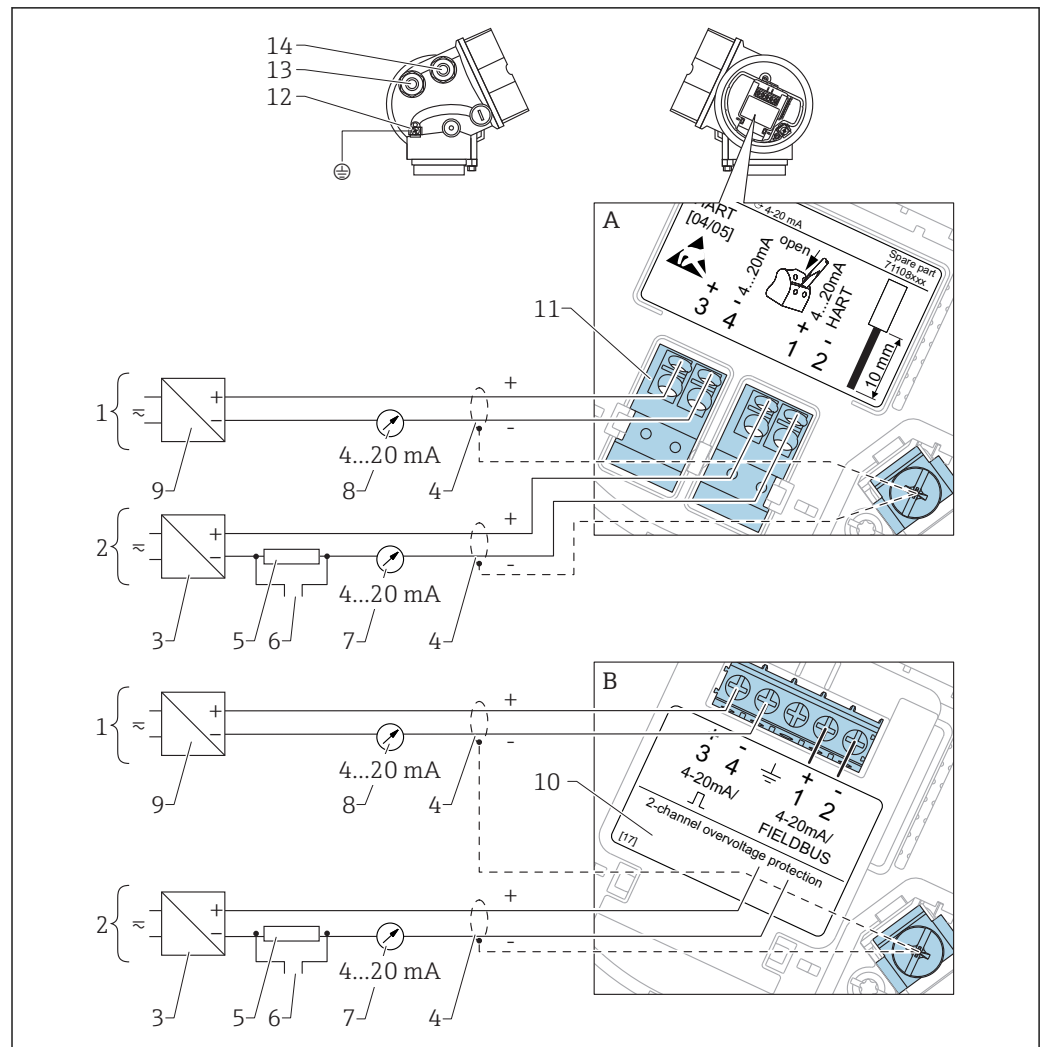

A0013923

4 Terminal assignment 2-wire, 4-20 mA HART, 4...20mA

- A Without integrated overvoltage protection
- B With integrated overvoltage protection
- 1 Connection current output 2
- 2 Connection current output 1
- 3 Supply voltage for current output 1 (e.g. RN221N); Observe terminal voltage
- 4 Cable screen; observe cable specification
- 5 HART communication resistor ($\geq 250 \Omega$); Observe maximum load
- 6 Connection for Commubox FXA195 or FieldXpert SFX350/SFX370 (via VIATOR Bluetooth modem)
- 7 Analog display device ; observe maximum load
- 8 Analog display device ; observe maximum load
- 9 Supply voltage for current output 2 (e.g. RN221N); Observe terminal voltage
- 10 Overvoltage protection module
- 11 Current output 2: Terminals 3 and 4
- 12 Terminal for the potential equalization line
- 13 Cable entry for current output 1
- 14 Cable entry for current output 2

i This version is also suited for single-channel operation. In this case, current output 1 (terminals 1 and 2) must be used.

4-wire: 4-20mA HART (10.4 to 48 V_{DC})

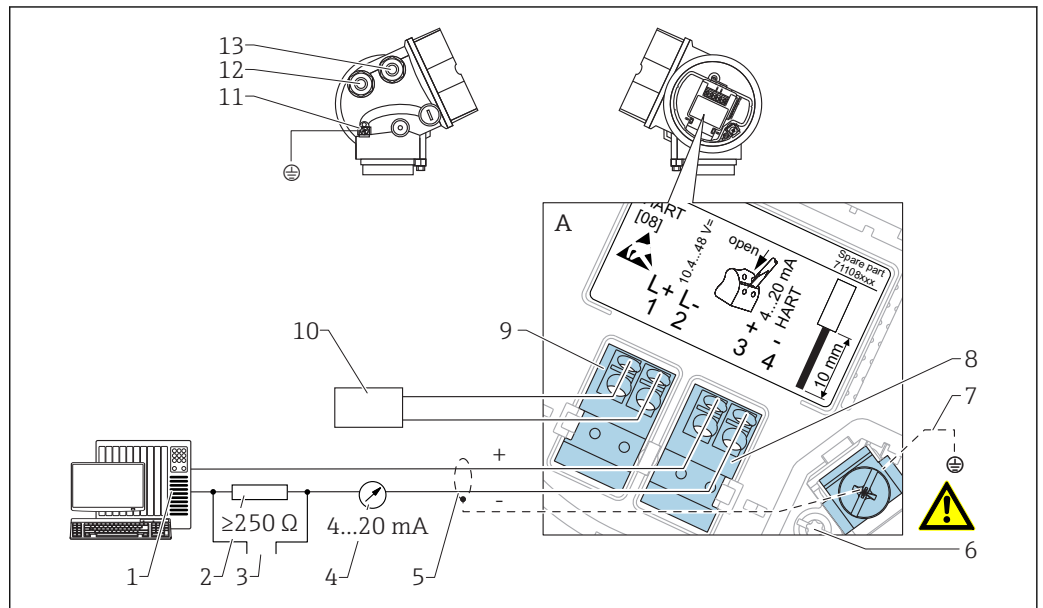

A0011340

5 Terminal assignment 4-wire; 4-20mA HART (10.4 to 48 V_{DC})

- 1 Evaluation unit, e.g. PLC
- 2 HART communication resistor ($\geq 250 \Omega$): Observe maximum load
- 3 Connection for Commubox FXA195 or FieldXpert SFX350/SFX370 (via VIATOR Bluetooth modem)
- 4 Analog display device: Observe maximum load
- 5 Signal cable including screening (if required), observe cable specification
- 6 Protective connection; do not disconnect!
- 7 Protective earth, observe cable specification
- 8 4...20mA HART (active): Terminals 3 and 4
- 9 Supply voltage: Terminals 1 and 2
- 10 Supply voltage: Observe terminal voltage, observe cable specification
- 11 Terminal for potential equalization
- 12 Cable entry for signal line
- 13 Cable entry for power supply

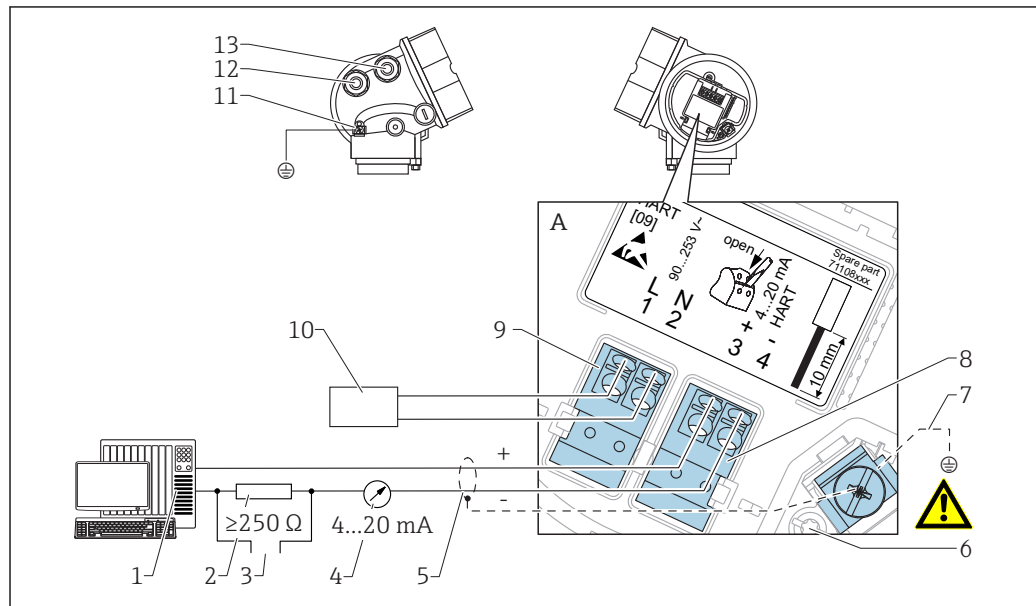
4-wire: 4-20mA HART (90 to 253 V_{AC})

A0018965

6 Terminal assignment 4-wire; 4-20mA HART (90 to 253 V_{AC})

- 1 Evaluation unit, e.g. PLC
- 2 HART communication resistor ($\geq 250 \Omega$): Observe maximum load
- 3 Connection for Commubox FXA195 or FieldXpert SFX350/SFX370 (via VIATOR Bluetooth modem)
- 4 Analog display device: Observe maximum load
- 5 Signal cable including screening (if required), observe cable specification
- 6 Protective connection; do not disconnect!
- 7 Protective earth, observe cable specification
- 8 4...20mA HART (active): Terminals 3 and 4
- 9 Supply voltage: Terminals 1 and 2
- 10 Supply voltage: Observe terminal voltage, observe cable specification
- 11 Terminal for potential equalization
- 12 Cable entry for signal line
- 13 Cable entry for power supply

CAUTION

To ensure electrical safety:

- ▶ Do not disconnect the protective connection (6).
- ▶ Disconnect the supply voltage before disconnecting the protective earth (7).

- i** Connect protective earth to the internal ground terminal (7) before connecting the supply voltage. If necessary, connect the potential matching line to the external ground terminal (11).
- i** In order to ensure electromagnetic compatibility (EMC): Do not only ground the device via the protective earth conductor of the supply cable. Instead, the functional grounding must also be connected to the process connection (flange or threaded connection) or to the external ground terminal.
- i** An easily accessible power switch must be installed in the proximity of the device. The power switch must be marked as a disconnecter for the device (IEC/EN61010).

PROFIBUS PA / FOUNDATION Fieldbus

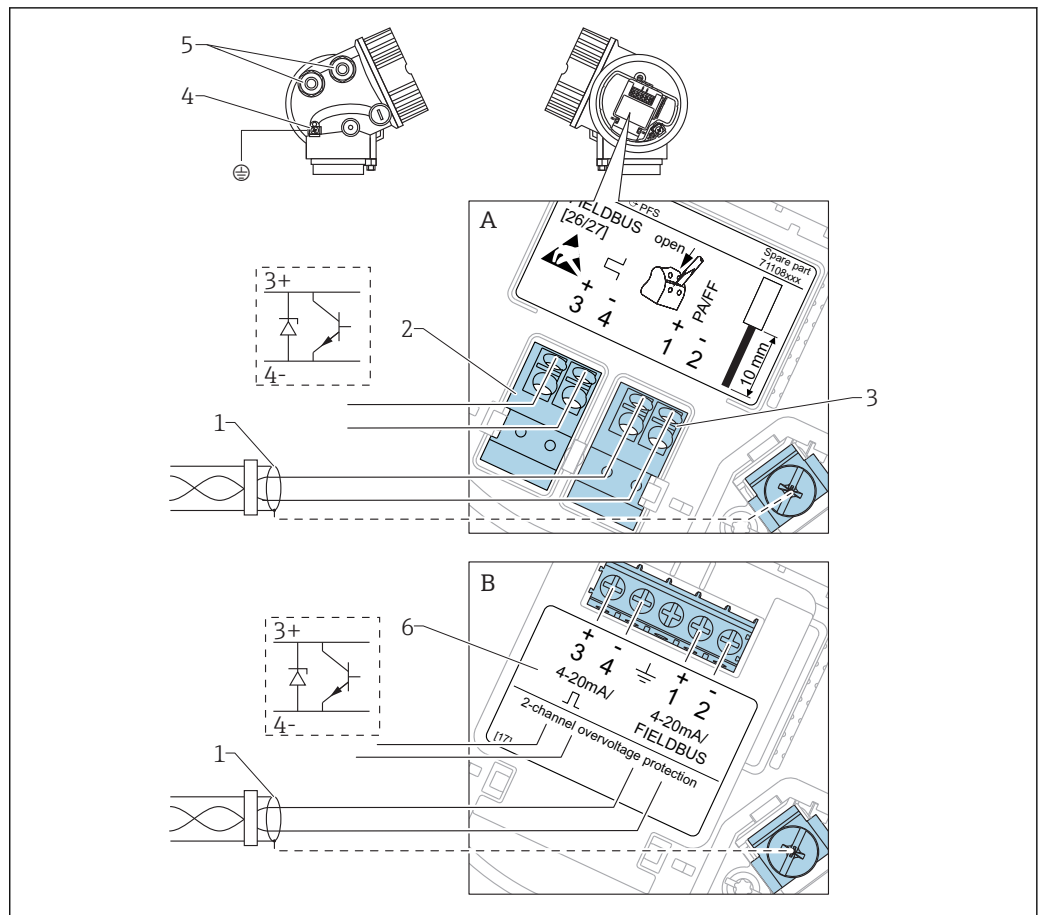

A0011341

7 Terminal assignment PROFIBUS PA / FOUNDATION Fieldbus

- A Without integrated overvoltage protection
- B With integrated overvoltage protection
- 1 Cable screen: Observe cable specifications
- 2 Switch output (open collector): Terminals 3 and 4
- 3 PROFIBUS PA / FOUNDATION Fieldbus: Terminals 1 and 2
- 4 Terminal for potential equalization line
- 5 Cable entries
- 6 Overvoltage protection module

Connection examples for the switch output

i For HART devices, the switch output is available as an option. See product structure, feature 20: "Power Supply, Output", option B: "2-wire; 4-20mA HART, switch output"

Devices with PROFIBUS PA and FOUNDATION Fieldbus always have a switch output.

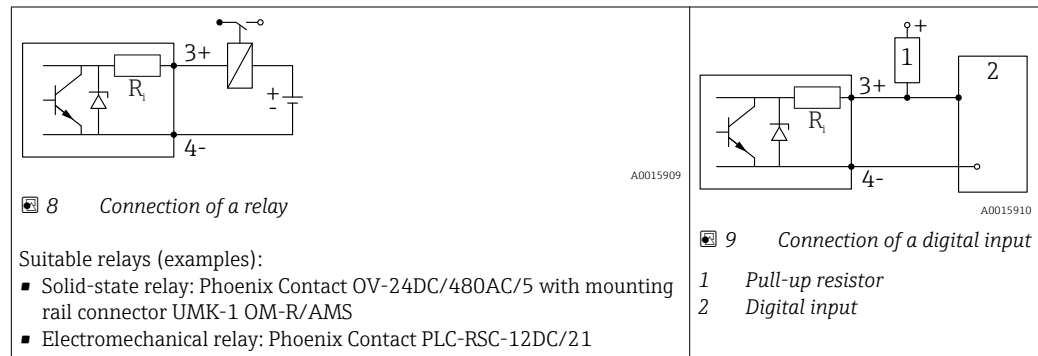

i For optimum interference immunity we recommend to connect an external resistor (internal resistance of the relay or Pull-up resistor) of $< 1\ 000\ \Omega$.

Device plug connectors



For the versions with fieldbus plug connector (M12 or 7/8"), the signal line can be connected without opening the housing.

Pin assignment of the M12 plug connector

<p style="text-align: right; font-size: small;">A0011175</p>	Pin	Meaning
	1	Signal +
	2	not connected
	3	Signal -
	4	Ground

Pin assignment of the 7/8" plug connector

<p style="text-align: right; font-size: small;">A0011176</p>	Pin	Meaning
	1	Signal -
	2	Signal +
	3	Not connected
	4	Screen

Supply voltage

An external power supply is required.

 Various supply units can be ordered from Endress+Hauser: see "Accessories" section →  97

2-wire, 4-20mA HART, passive

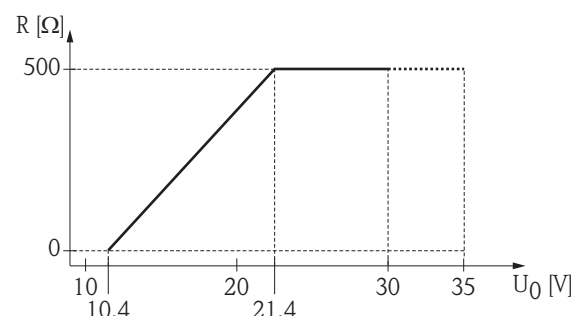
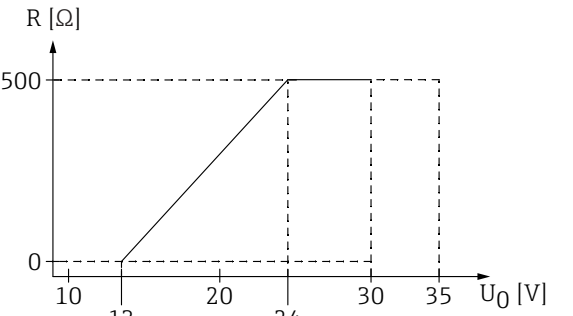
"Power Supply, Output" ¹⁾	"Approval" ²⁾	Terminal voltage U at the device	Maximum load R, depending on the supply voltage U ₀ at the supply unit
A: 2-wire; 4-20mA HART	<ul style="list-style-type: none"> ■ Non-Ex ■ Ex nA ■ Ex ic ■ CSA GP 	10.4 to 35 V ^{3) 4)}	 <p style="text-align: right; font-size: small;">A0017140</p>
	Ex ia / IS	10.4 to 30 V ^{3) 4)}	
	<ul style="list-style-type: none"> ■ Ex d(ia) / XP ■ Ex ic(ia) ■ Ex nA(ia) ■ Ex ta / DIP 	13 to 35 V ⁵⁾	 <p style="text-align: right; font-size: small;">A0034771</p>
	Ex ia + Ex d(ia) / IS + XP	13 to 30 V ⁵⁾	

- 1) Feature 020 of the product structure
- 2) Feature 010 of the product structure
- 3) For ambient temperatures T_a ≤ -20 °C (-4 °F) a minimum voltage of 15 V is required for the startup of the device at the MIN error current (3,6 mA). The startup current can be parametrized. If the device is operated with a fixed current I ≥ 5,5 mA (HART multidrop mode), a voltage of U ≥ 10,4 V is sufficient throughout the entire range of ambient temperatures.
- 4) In the current simulation mode a voltage U ≥ 12.5 V is required.
- 5) For ambient temperatures T_a ≤ -20 °C (-4 °F) a minimum voltage of 16 V is required for the startup of the device at the MIN error current (3.6 mA).

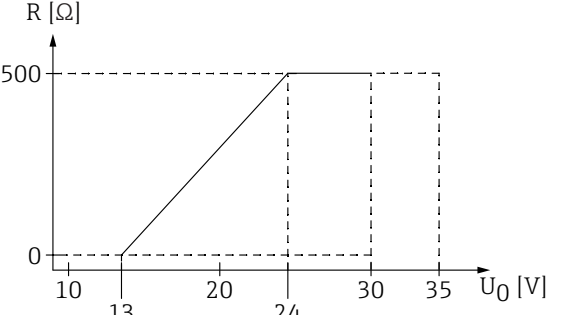
"Power Supply, Output" ¹⁾	"Approval" ²⁾	Terminal voltage U at the device	Maximum load R, depending on the supply voltage U ₀ at the supply unit
B: 2-wire; 4-20 mA HART, switch output	<ul style="list-style-type: none"> ■ Non-Ex ■ Ex nA ■ Ex nA(ia) ■ Ex ic ■ Ex ic(ia) ■ Ex d(ia) / XP ■ Ex ta / DIP ■ CSA GP 	13 to 35 V ³⁾	 <p style="text-align: right; font-size: small;">A0034771</p>
	<ul style="list-style-type: none"> ■ Ex ia / IS ■ Ex ia + Ex d(ia) / IS + XP 	13 to 30 V ³⁾	

- 1) Feature 020 of the product structure
- 2) Feature 010 of the product structure
- 3) For ambient temperatures T_a ≤ -30 °C (-22 °F) a minimum voltage of 16 V is required for the startup of the device at the MIN error current (3.6 mA).

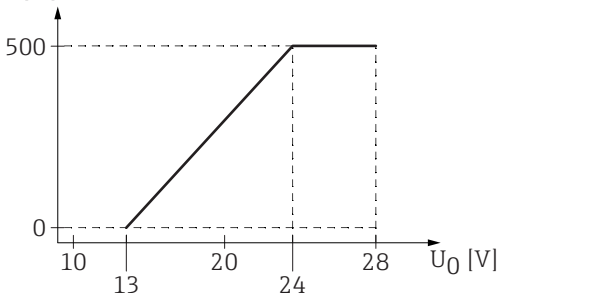
"Power Supply, Output" ¹⁾	"Approval" ²⁾	Terminal voltage U at the device	Maximum load R, depending on the supply voltage U ₀ at the supply unit
C: 2-wire; 4-20mA HART, 4-20mA	any	13 to 28 V ³⁾	 <p>The graph plots Maximum load R [Ω] on the y-axis (0 to 500) against supply voltage U₀ [V] on the x-axis (10 to 28). The load is 0 Ω for U₀ < 13 V. It increases linearly from 0 Ω at 13 V to 500 Ω at 24 V. It remains constant at 500 Ω for U₀ between 24 V and 28 V.</p>

A0034841

- 1) Feature 020 of the product structure
- 2) Feature 010 of the product structure
- 3) For ambient temperatures $T_a \leq -30 \text{ }^\circ\text{C}$ ($-22 \text{ }^\circ\text{F}$) a minimum voltage of 16 V is required for the startup of the device at the MIN error current (3.6 mA).

Polarity reversal protection	Yes
Admissible residual ripple at f = 0 to 100 Hz	$U_{SS} < 1 \text{ V}$
Admissible residual ripple at f = 100 to 10000 Hz	$U_{SS} < 10 \text{ mV}$

4-wire, 4-20mA HART, active

"Power supply; Output" ¹⁾	Terminal voltage	Maximum load R_{max}
K: 4-wire 90-253VAC; 4-20mA HART	90 to 253 V _{AC} (50 to 60 Hz), overvoltage category II	500 Ω
L: 4-wire 10,4-48VDC; 4-20mA HART	10.4 to 48 V _{DC}	

1) Feature 020 of the product structure

PROFIBUS PA, FOUNDATION Fieldbus

"Power supply; Output" ¹⁾	"Approval" ²⁾	Terminal voltage
E: 2-wire; FOUNDATION Fieldbus, switch output G: 2-wire; PROFIBUS PA, switch output	<ul style="list-style-type: none"> ▪ Non-Ex ▪ Ex nA ▪ Ex nA(ia) ▪ Ex ic ▪ Ex ic(ia) ▪ Ex d(ia) / XP ▪ Ex ta / DIP ▪ CSA GP 	9 to 32 V ³⁾
	<ul style="list-style-type: none"> ▪ Ex ia / IS ▪ Ex ia + Ex d(ia) / IS + XP 	9 to 30 V ³⁾

1) Feature 020 of the product structure

2) Feature 010 of the product structure

3) Input voltages up to 35 V will not spoil the device.

Polarity sensitive	No
FISCO/FNICO compliant according to IEC 60079-27	Yes

Power consumption

"Power supply; Output" ¹⁾	Power consumption
A: 2-wire; 4-20mA HART	< 0.9 W
B: 2-wire; 4-20mA HART, switch output	< 0.9 W
C: 2-wire; 4-20mA HART, 4-20mA	< 2 x 0.7 W
K: 4-wire 90-253VAC; 4-20mA HART	6 VA
L: 4-wire 10,4-48VDC; 4-20mA HART	1.3 W

1) Feature 020 of the product structure

Current consumption**HART**

Nominal current	3.6 to 22 mA, the start-up current for multidrop mode can be parametrized (is set to 3.6 mA on delivery)
Breakdown signal (NAMUR NE43)	adjustable: 3.59 to 22.5 mA

PROFIBUS PA

Nominal current	14 mA
Error current FDE (Fault Disconnection Electronic)	0 mA

FOUNDATION Fieldbus

Device basic current	15 mA
Error current FDE (Fault Disconnection Electronic)	0 mA

FISCO

U_i	17.5 V
I_i	550 mA
P_i	5.5 W
C_i	5 nF
L_i	10 μ H

Power supply failure

- Configuration is retained in the HistoROM (EEPROM).
- Error messages (incl. value of operated hours counter) are stored.

Potential equalization

No special measures for potential equalization are required.



If the device is designed for hazardous areas, observe the information in the documentation "Safety Instructions" (XA).

Terminals

- **Without integrated overvoltage protection**
Plug-in spring terminals for wire cross-sections 0.5 to 2.5 mm² (20 to 14 AWG)
- **With integrated overvoltage protection**
Screw terminals for wire cross-sections 0.2 to 2.5 mm² (24 to 14 AWG)

Cable entries

Connection of power supply and signal line

To be selected in feature 050 "Electrical connection"

- Gland M20; Material dependent on the approval:
 - For Non-Ex, ATEX, IECEx, NEPSI Ex ia/ic:
Plastics M20x1.5 for cable \varnothing 5 to 10 mm (0.2 to 0.39 in)
 - For Dust-Ex, FM IS, CSA IS, CSA GP, Ex nA:
 - For Ex d:
No gland available
- Thread
 - 1/2" NPT
 - G 1/2"
 - M20 \times 1.5
- Plug M12 / Plug 7/8"
Only available for Non-Ex, Ex ic, Ex ia

Connection of remote display FHX50

Dependent on feature 030: "Display, Operation":

- "Prepared for display FHX50 + M12 connection":
M12 socket
- "Prepared for display FHX50 + custom connection":
M16 cable gland

Cable specification

- **Devices without integrated overvoltage protection**
Pluggable spring-force terminals for wire cross-sections 0.5 to 2.5 mm² (20 to 14 AWG)
- **Devices with integrated overvoltage protection**
Screw terminals for wire cross-sections 0.2 to 2.5 mm² (24 to 14 AWG)
- For ambient temperature $T_U \geq 60$ °C (140 °F): use cable for temperature $T_U + 20$ K.

HART

- A normal device cable suffices if only the analog signal is used.
- A shielded cable is recommended if using the HART protocol. Observe grounding concept of the plant.
- For 4-wire devices: Standard device cable is sufficient for the power line.

PROFIBUS

Use a twisted, screened two-wire cable, preferably cable type A.

-  For further information on the cable specifications, see Operating Instructions BA00034S "PROFIBUS DP/PA: Guidelines for planning and commissioning", PNO Guideline 2.092 "PROFIBUS PA User and Installation Guideline" and IEC 61158-2 (MBP).

FOUNDATION Fieldbus

Endress+Hauser recommends using twisted, shielded two-wire cables.

-  For further information on the cable specifications, see Operating Instructions BA00013S "FOUNDATION Fieldbus Overview", FOUNDATION Fieldbus Guideline and IEC 61158-2 (MBP).

Overvoltage protection

If the measuring device is used for level measurement in flammable liquids which requires the use of overvoltage protection according to DIN EN 60079-14, standard for test procedures 60060-1 (10 kA, pulse 8/20 μ s), overvoltage protection has to be ensured by an integrated or external overvoltage protection module.

Integrated overvoltage protection

An integrated overvoltage protection module is available for 2-wire HART as well as PROFIBUS PA and FOUNDATION Fieldbus devices.

Product structure: Feature 610 "Accessory mounted", option NA "Overvoltage protection".

Technical data	
Resistance per channel	2 \times 0.5 Ω max.
Threshold DC voltage	400 to 700 V
Threshold impulse voltage	< 800 V
Capacitance at 1 MHz	< 1.5 pF
Nominal arrest impulse voltage (8/20 μ s)	10 kA

External overvoltage protection

HAW562 or HAW569 from Endress+Hauser are suited as external overvoltage protection.

-  For detailed information please refer to the following documents:
- HAW562: TI01012K
 - HAW569: TI01013K

Performance characteristics

Reference operating conditions

- Temperature = +24 °C (+75 °F) ±5 °C (±9 °F)
- Pressure = 960 mbar abs. (14 psia) ±100 mbar (±1.45 psi)
- Humidity = 60 % ±15 %
- Reflector: metal plate with a minimum diameter of 1 m (40 in)
- No major interference reflections inside the signal beam

Maximum measured error

Typical data under reference operating conditions: DIN EN IEC 61298-2 / DIN EN IEC 60770-1; percentage values in relation to the span.

Device	Value	Output	
		digital	analog ¹⁾
FMR56/FMR57	Sum of non-linearity, nonrepeatability and hysteresis	± 3 mm (0.12 in)	± 0.02 %
	Offset/Zero	± 4 mm (0.2 in)	± 0.03 %

1) Only relevant for 4-20mA current output; add error of the analog value to the digital value.

Differing values in near-range applications

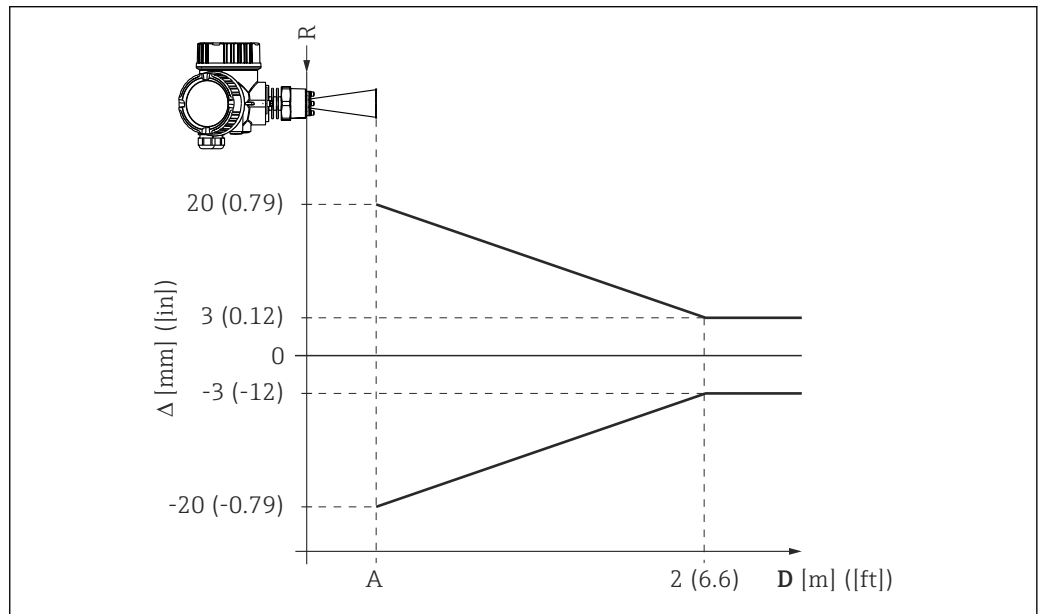

10 Maximum measured error in near-range applications

- Δ Maximum measured error
- A Lower edge of the antenna
- D Distance from the lower edge A of the antenna
- R Reference point of the distance measurement

Measured value resolution

Dead band according to DIN EN IEC 61298-2 / DIN EN IEC 60770-1:

- digital: 1 mm
- analog: 1 μ A

Reaction time

The reaction time can be parametrized. The following step response times (as per DIN EN IEC 61298-2 / DIN EN IEC 60770-1) ¹⁾ are valid if the damping is switched off:

Tank height	Sampling rate	Step response time
< 10 m (33 ft)	$\geq 3.6 \text{ s}^{-1}$	< 0.8 s
< 70 m (230 ft)	$\geq 2.2 \text{ s}^{-1}$	< 1 s

Influence of ambient temperature

The measurements are carried out in accordance with DIN EN IEC 61298-3 / DIN EN IEC 60770-1

- Digital (HART, PROFIBUS PA, FOUNDATION Fieldbus): average $T_K = 3 \text{ mm}/10 \text{ K}$
- Analog (current output):
 - zero point (4 mA): average $T_K = 0.02 \text{ %}/10 \text{ K}$
 - span (20 mA): average $T_K = 0.05 \text{ %}/10 \text{ K}$

1) According to DIN EN IEC 61298-2 / DIN EN IEC 60770-1 the response time is the time which passes after a sudden change of the input signal until the output signal for the first time assumes 90% of the steady-state value.

Installation

Installation conditions

Mounting position

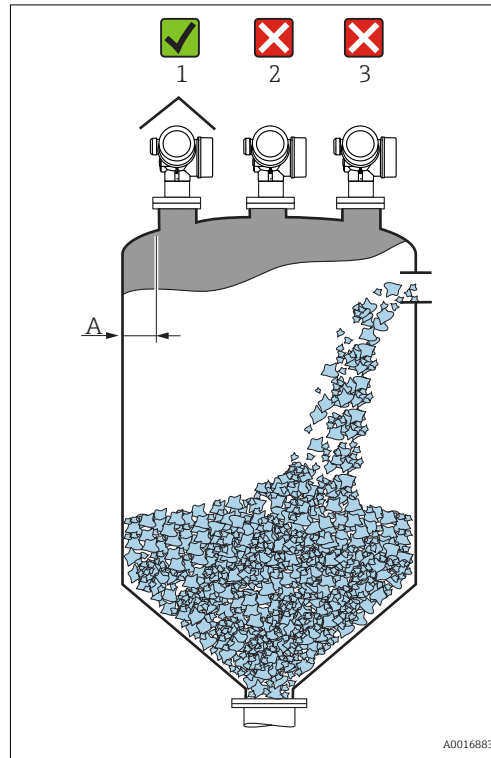

- Recommended distance **A** from wall to outer edge of nozzle: $\sim 1/6$ of vessel diameter. Nevertheless the device should not be installed closer than 20 cm (7.87 in) to the vessel wall. If the wall of the vessel is not smooth (corrugated metal, welding seams, irregularities etc.) the distance from the wall should be kept as large as possible. If necessary, use an alignment device to prevent interference reflections from the wall \rightarrow 41.
- Not in the center (2), as interference can cause signal loss.
- Not above the fill stream (3).
- It is recommended to use a weather protection cover (1) in order to protect the device from direct sun or rain.
- In extremely dusty applications, the integrated air purge connection can prevent clogging of the antenna \rightarrow 41.

Vessel installations

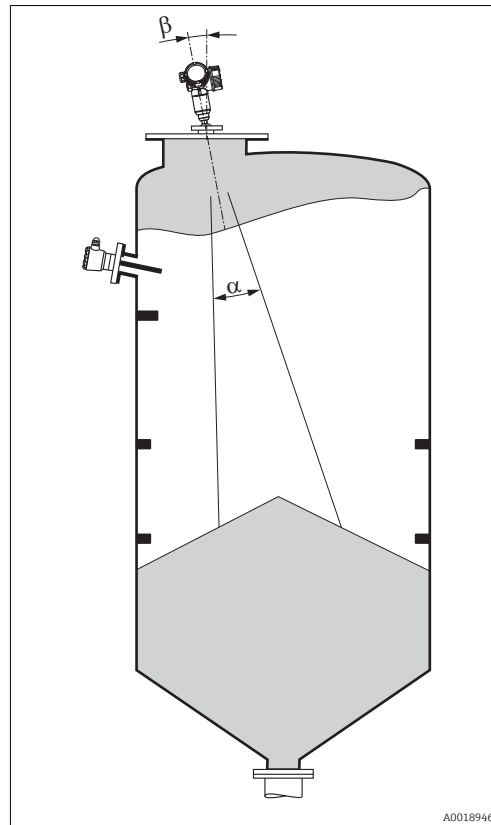

Avoid any installations (limit switches, temperature sensors, braces etc.) inside the signal beam. Take into account the beam angle \rightarrow 34.

Reduction of interference echoes

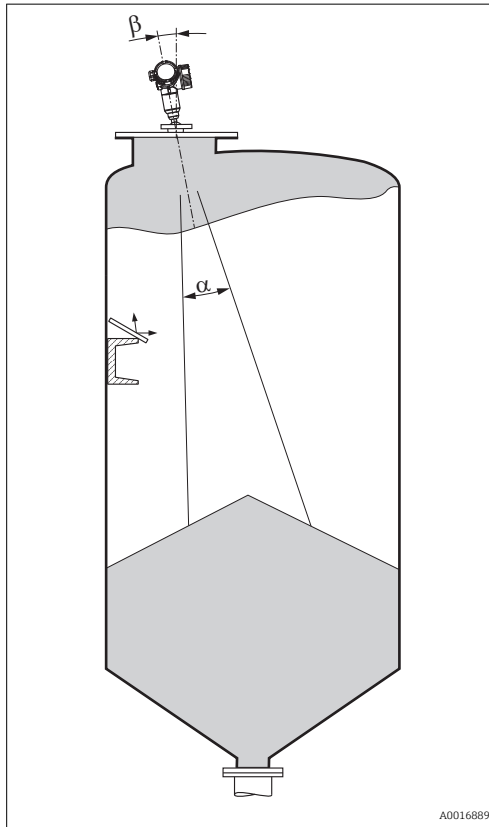

Metallic screens mounted at a slope spread the radar signal and can, therefore, reduce interference echoes.

Measurement in a plastic vessel

If the outer wall of the vessel is made of a non-conductive material (e.g. GRP), microwaves can also be reflected off interfering installations outside the vessel (e.g. metallic pipes (1), ladders (2), grates (3), ...). Therefore, there should be no such interfering installations in the signal beam. Please contact Endress+Hauser for further information.

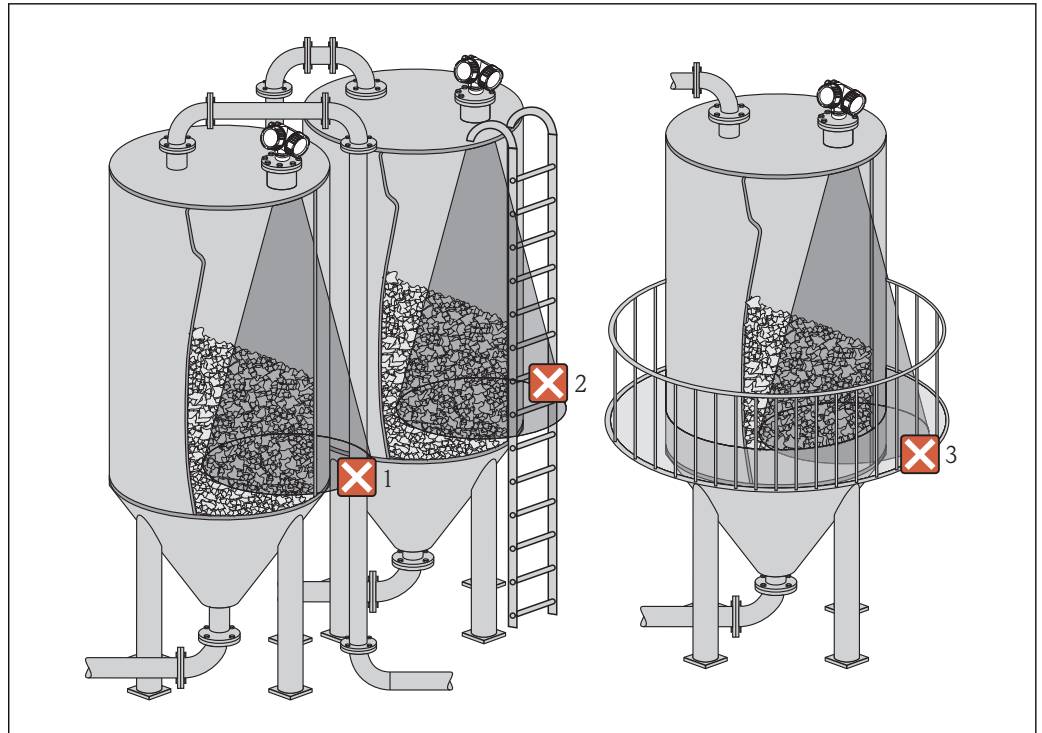

A0017125

Optimization options

- **Antenna size**
The bigger the antenna, the smaller the beam angle α and the fewer interference echoes
→ ☰ 34.
- **Mapping**
The measurement can be optimized by means of electronic suppression of interference echoes.
- **Antenna alignment**
Take into account the marker on the flange or threaded connection → ☰ 37.
- **Metallic screens mounted at a slope**
They spread the radar signals and can, therefore, reduce interference echoes.
- **Variable flange seal (FMR56)**
Using the variable flange seal, the device can be aligned in the direction of the product surface. For details refer to Operating Instructions BA01048F, chapter "Accessories".
- **Alignment device for FMR57**
In FMR57 with alignment device, the sensor can be optimally aimed within the vessel and thus interference echoes can be avoided. The maximum angle β is $\pm 15^\circ$.
In particular, sensor alignment serves to:
 - prevent interference reflections
 - extend the maximum possible measuring range in conical outlets

Beam angle

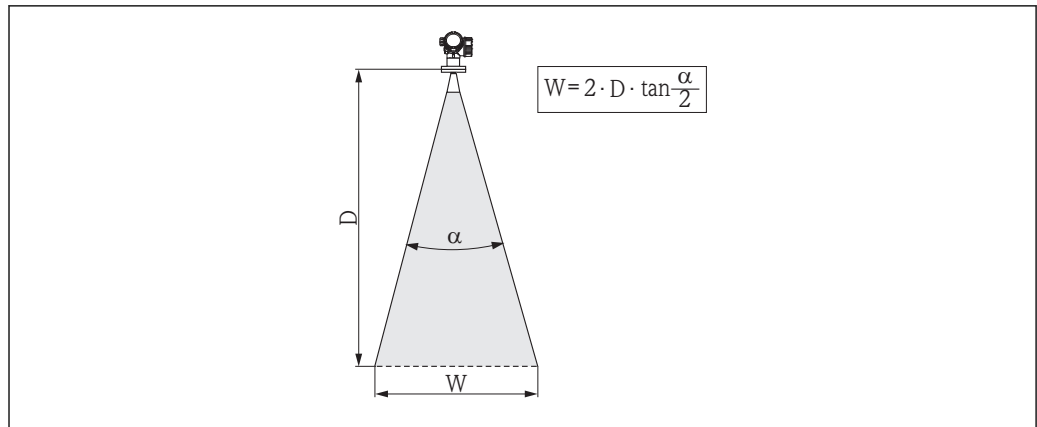

A0016891

11 Relationship between beam angle α , distance D and beamwidth diameter W

The beam angle is defined as the angle α where the energy density of the radar waves reaches half the value of the maximum energy density (3-dB-width). Microwaves are also emitted outside the signal beam and can be reflected off interfering installations.

Beam diameter W as a function of beam angle α and measuring distance D :

FMR56		
Antenna size	80 mm (3 in)	100 mm (4 in)
Beam angle α	10°	8°
Measuring distance (D)	Beamwidth diameter (W)	
3 m (9.8 ft)	0.53 m (1.7 ft)	0.42 m (1.4 ft)
6 m (20 ft)	1.05 m (3.4 ft)	0.84 m (2.8 ft)
9 m (30 ft)	1.58 m (5.2 ft)	1.26 m (4.1 ft)
12 m (39 ft)	2.1 m (6.9 ft)	1.68 m (5.5 ft)
15 m (49 ft)	2.63 m (8.6 ft)	2.10 m (6.9 ft)
20 m (66 ft)	3.50 m (11 ft)	2.80 m (9.2 ft)
25 m (82 ft)	4.37 m (14 ft)	3.50 m (11 ft)
30 m (98 ft)	5.25 m (17 ft)	4.20 m (14 ft)

FMR57 - Horn antenna		
Antenna size	80 mm (3 in)	100 mm (4 in)
Beam angle α	10°	8°
Measuring distance (D)	Beamwidth diameter W	
5 m (16 ft)	0.87 m (2.9 ft)	0.7 m (2.3 ft)
10 m (33 ft)	1.75 m (5.7 ft)	1.4 m (4.6 ft)
15 m (49 ft)	2.62 m (8.6 ft)	2.1 m (6.9 ft)
20 m (66 ft)	3.50 m (11 ft)	2.80 m (9.2 ft)
30 m (98 ft)	5.25 m (17 ft)	4.20 m (14 ft)
40 m (131 ft)	7.00 m (23 ft)	5.59 m (18 ft)
50 m (164 ft)	8.75 m (29 ft)	6.99 m (23 ft)

FMR57 - Parabolic antenna		
Antenna size	200 mm (8 in)	250 mm (10 in)
Beam angle α	4°	3,5°
Measuring distance (D)	Beamwidth diameter W	
5 m (16 ft)	0.35 m (1.1 ft)	0.30 m (1 ft)
10 m (33 ft)	0.70 m (2.3 ft)	0.61 m (2 ft)
15 m (49 ft)	1.05 m (3.4 ft)	0.92 m (3 ft)
20 m (66 ft)	1.40 m (4.6 ft)	1.22 m (4 ft)
30 m (98 ft)	2.10 m (6.9 ft)	1.83 m (6 ft)
40 m (131 ft)	2.79 m (9.2 ft)	2.44 m (8 ft)
50 m (164 ft)	3.50 m (11 ft)	3.06 m (10 ft)
60 m (197 ft)	4.19 m (14 ft)	3.70 m (12 ft)
70 m (230 ft)	4.90 m (16 ft)	4.28 m (14 ft)

Measuring conditions

- The measuring range begins, where the beam hits the bottom. Particularly with conical outlets the level cannot be detected below this point. The maximum measuring range can be increased in such applications by using an alignment device → 41.
- In case of media with a low dielectric constant ($\epsilon_r = 1.5$ to 2.5)²⁾, the bottom can be visible through the medium at low levels. In order to guarantee the required accuracy in these cases, it is recommended to position the zero-point at a distance **C** above the bottom (see figure).
- In principle it is possible to measure up to the tip of the antenna with Micropilot. However, due to considerations regarding abrasion and build-up and depending on the orientation of the product surface (angle of repose), the end of the measuring range should be at a distance of **A** (see figure) from the tip of the antenna. If required, and if some conditions (high DC value, flat angle of repose) are met, shorter distances can be achieved.

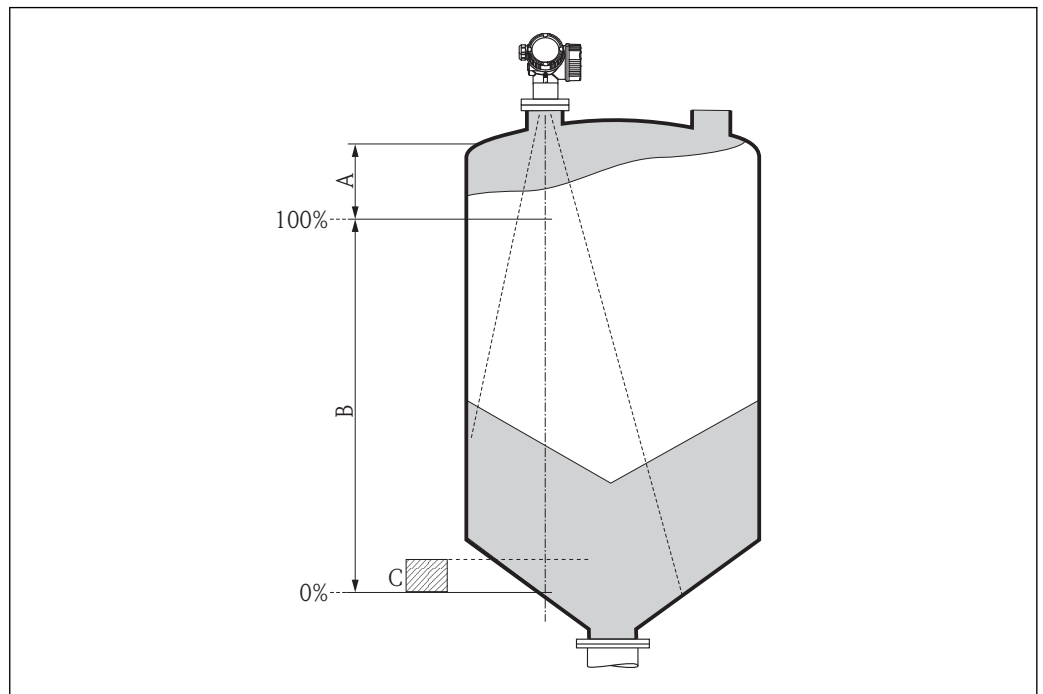

A0016916

2) Dielectric constants of important media commonly used in various industries are summarized in the DC manual (CP01076F) and in the Endress +Hauser "DC Values App" (available for Android and iOS).

Device	A [mm (in)]	C [mm (in)]
FMR56	400(15.7)	50 to 150(1.97 to 5.91)
FMR57		

Installation in vessel (free space)

Horn antenna with slip-on flange (FMR56)

Alignment

i When using the Micropilot with a slip-on flange in explosion-hazardous areas, strictly observe all specifications in the relevant Safety Instructions (XA).

- Align the antenna vertically to the product surface.
Optionally, a variable flange seal, which is available as an accessory, can be used for alignment (see Technical Information BA01048F, chapter "Accessories").
- A marking at the boss enables alignment of the antenna. This marking must be aligned towards the tank wall as well as possible.

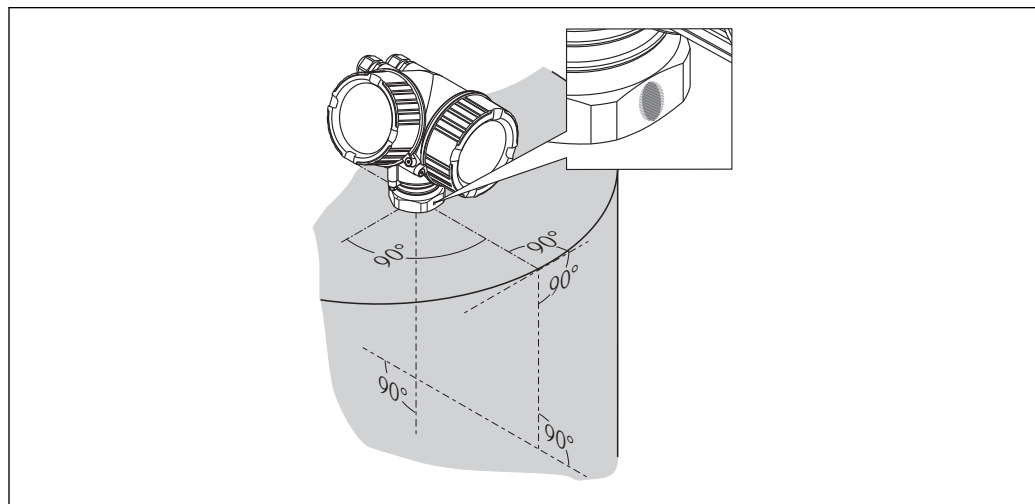

A0019434

i Depending on the device version the marking may be a circle or two short parallel lines.

Nozzle mounting

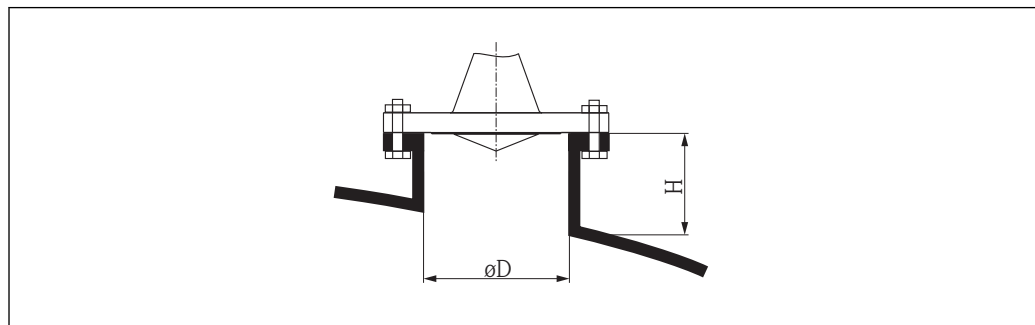

A0016868

12 Nozzle height and diameter for horn antenna with slip-on flange

Nozzle diameter D	Maximum nozzle height H_{max}
80 mm (3 in)	300 mm (11.8 in)
100 mm (4 in)	400 mm (15.8 in)
150 mm (6 in)	500 mm (19.7 in)

Horn antenna with mounting bracket (FMR56)

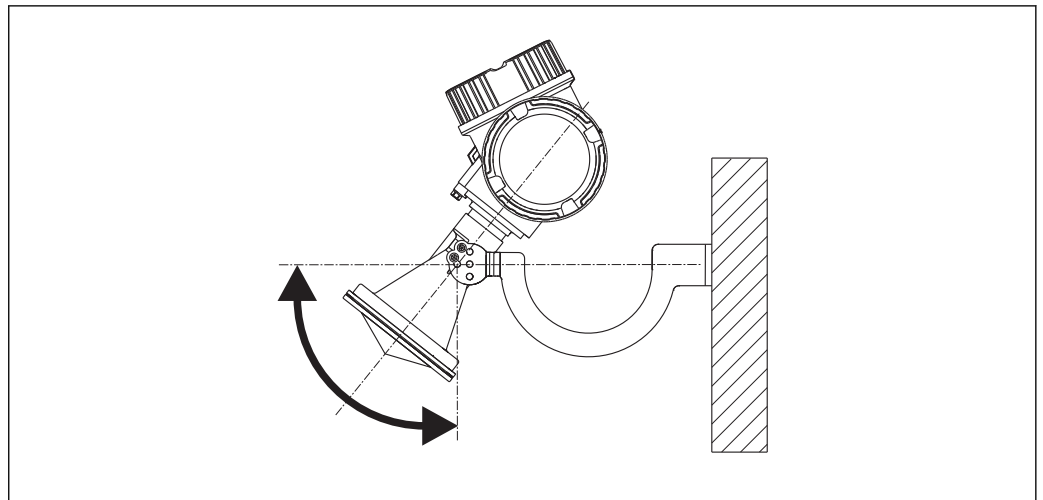

A0016865

13 Installation of the horn antenna with mounting bracket

Align the antenna vertically to the product surface using the mounting bracket.

NOTICE

The mounting bracket has no conductive connection to the transmitter housing.

Danger of electrostatic charge

- ▶ Connect the mounting bracket to the local potential equalization system.

Horn antenna (FMR57)

Alignment

- Ideally, the horn antenna should be installed vertically. To avoid interference reflections or for optimum alignment within the vessel, the Micropilot with optional alignment device can be inclined by 15° in all directions → 41.
- A marking at the boss enables alignment of the antenna. This marking must be aligned towards the tank wall as well as possible.

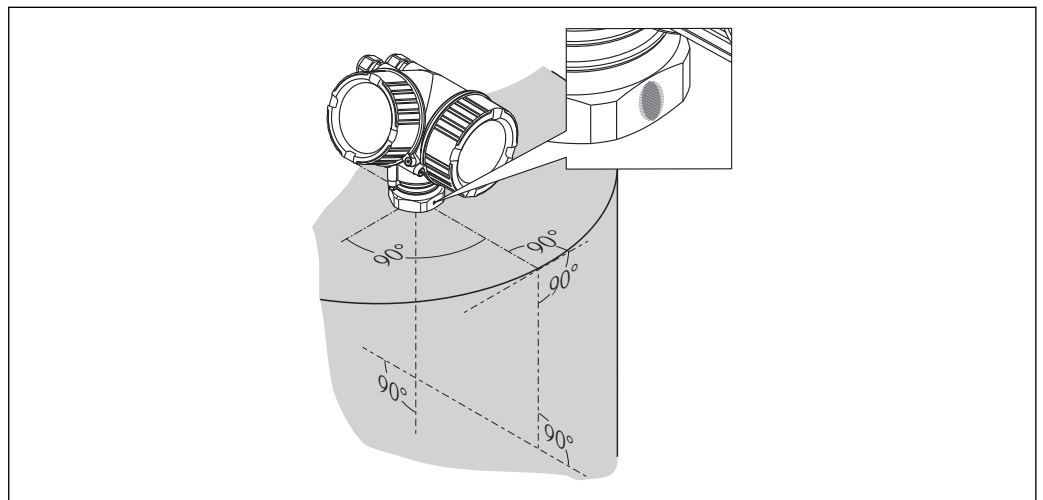

A0019434

-  Depending on the device version the marking may be a circle or two short parallel lines.

Nozzle mounting

The horn antenna should protrude from the nozzle. If this is not possible for mechanical reasons, larger nozzle heights can be accepted.

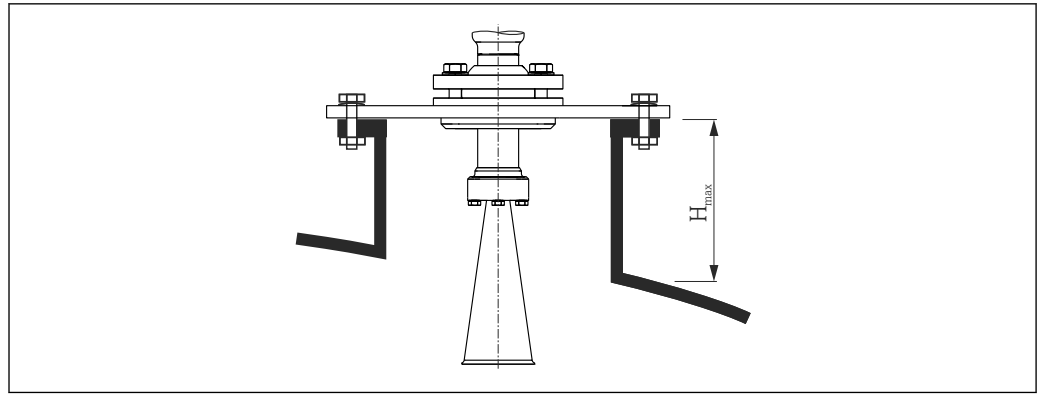

A0016825

14 Nozzle height for the horn antenna (FMR57)

Antenna ¹⁾	Maximum nozzle height H_{max} ²⁾
BC: Horn 80mm/3"	260 mm (10.2 in)
BD: Horn 100mm/4"	480 mm (18.9 in)

- 1) Feature 070 of the product structure
 2) valid for antennas without antenna extension

i Please contact Endress+Hauser for applications with higher nozzle.

Threaded connection

i For devices with a threaded connection it may be necessary - depending on the antenna size - to unmount the horn before fastening the device and to mount it again afterwards.

- Tighten with the hexagonal nut only.
- Tool : 60 mm hexagonal wrench
- Maximum permissible torque: 60 Nm (44 lbf ft)

Parabolic antenna (FMR57)

Alignment

Ideally, the parabolic antenna should be installed vertically. To avoid interference reflections or for optimum alignment within the vessel, the Micropilot with optional alignment device can be swiveled by 15° in all directions → 41.

Nozzle mounting

- Case 1: Ideally, the parabolic antenna should protrude from the nozzle (1). Particularly when using the alignment device, please ensure that the parabolic reflector is protruding from the nozzle/roof so as not to inhibit alignment.
- Case 2: For applications with higher nozzle it may be necessary to install the parabolic antenna completely in the nozzle (2).
 The maximum height of the nozzle (H_{max}) to the parabolic mirror should not exceed 500 mm (19.7 in). Interfering edges within the nozzle should be avoided.

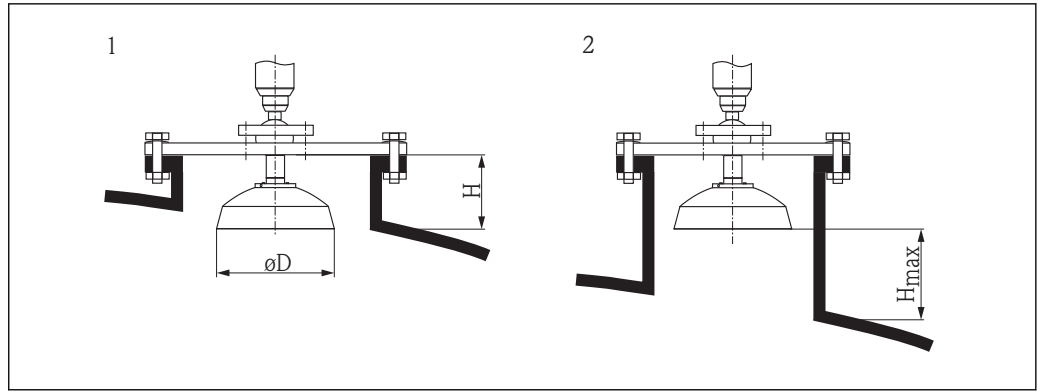

A0016827

15 Nozzle mounting of Micropilot FMR57 with parabolic antenna

- 1 Antenna protrudes from the nozzle
- 2 Antenna completely within the nozzle

Antenna ¹⁾	Antenna diameter D	Nozzle height H for case 1	Maximum nozzle height H_{max} for case 2
FA: Parabol 200mm/8"	173 mm (6.81 in)	< 50 mm (1.97 in)	500 mm (19.7 in)
FB: Parabol 250mm/10"	236 mm (9.29 in)	< 50 mm (1.97 in)	500 mm (19.7 in)

1) Feature 070 of the product structure

Examples for installation with small flange

If the flange is smaller than the parabolic reflector, the device can be mounted in one of the following ways:

- Standard installation → 39
This requires dismantling of the parabolic reflector.
- Installation with hinged flange → 40

Standard installation

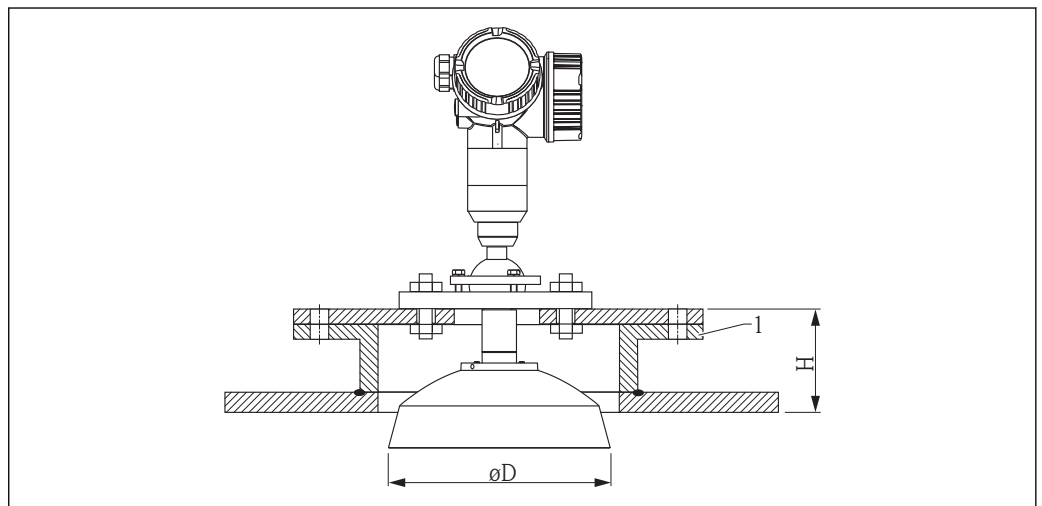

A0018874

1 Nozzle

Antenna size	ϕD	H ¹⁾
200 mm (8 in)	173 mm (6.81 in)	< 50 mm (1.96 in)
250 mm (10 in)	236 mm (9.29 in)	< 50 mm (1.96 in)

1) without antenna extension

Installation with hinged flange

 At hinged flanges, the length of the antenna must be taken into account.

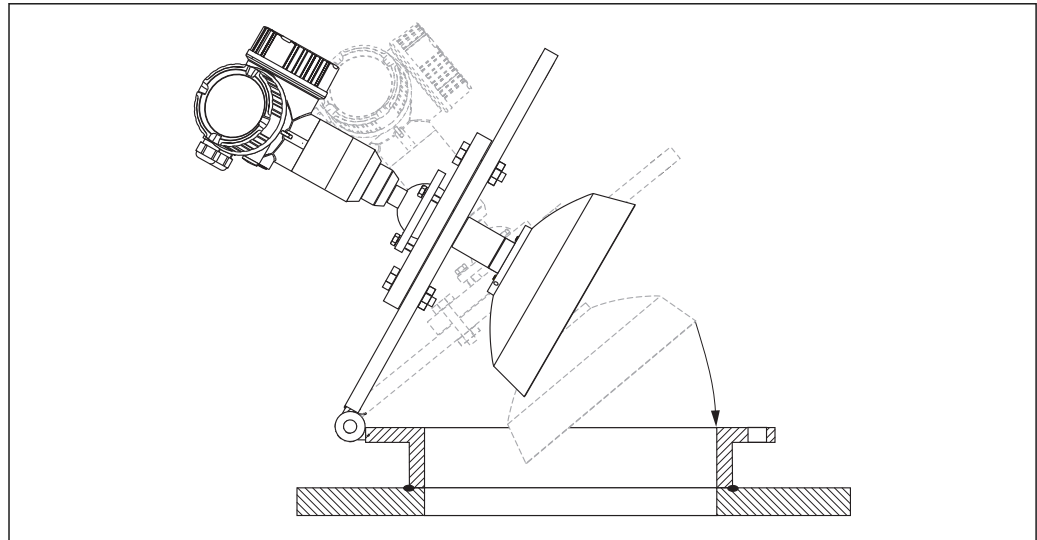

A0018878

Dismantling the parabolic reflector

For installation in a nozzle, the parabolic reflector can be dismantled:

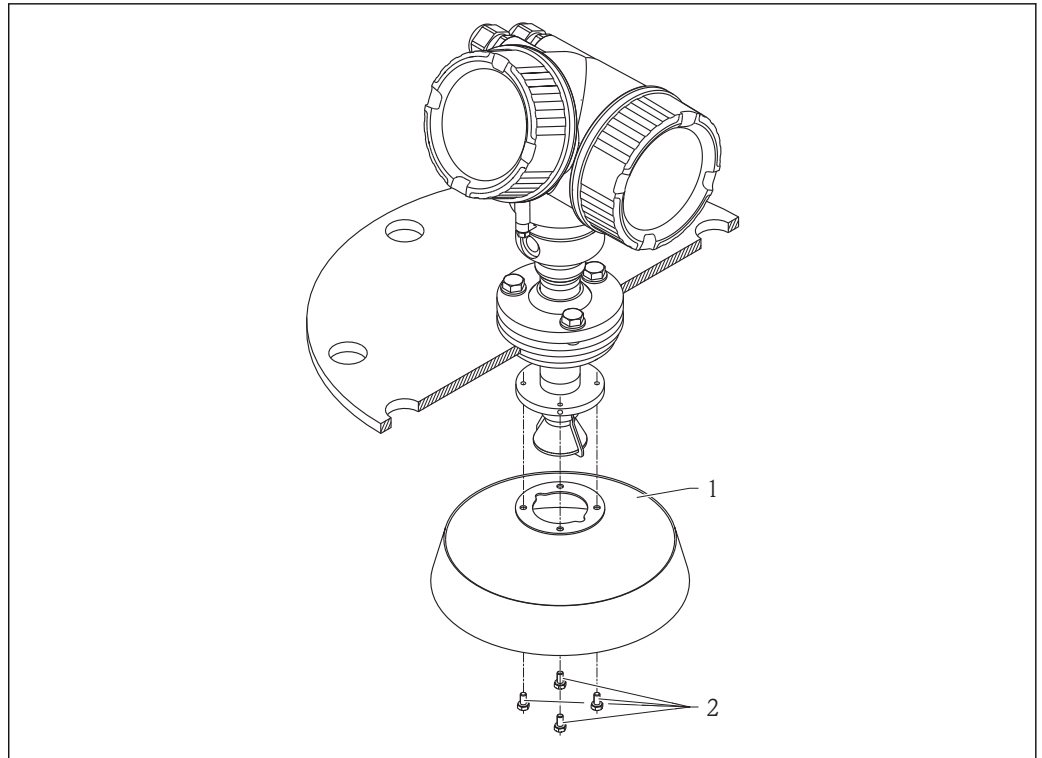

A0018877

- 1 Parabolic reflector
- 2 4 bolts; torque: 3 Nm (2,2 lbf ft)

Alignment device for FMR57

Using the alignment device it is possible to tilt the antenna axis by up to 15° in all directions. The alignment device is used for the optimum alignment of the radar beam with the bulk solids surface.

Product structure: Feature 100 "Process connection", options XCJ, XEJ, XFJ

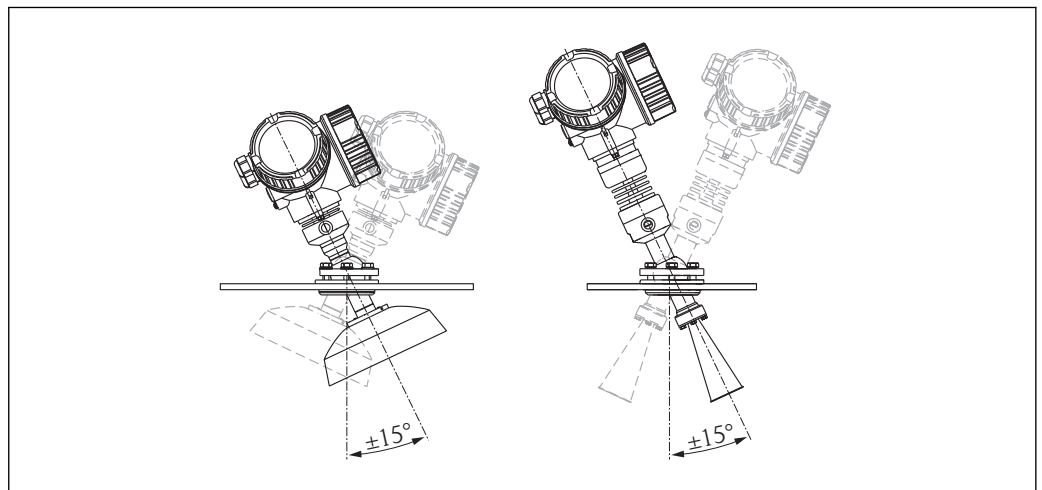

A0016931

16 Micropilot FMR57 with alignment device

Integrated air purge connection for FMR57

In extremely dusty applications, the integrated air purge connection can prevent clogging of the antenna. Pulsed operation is recommended.

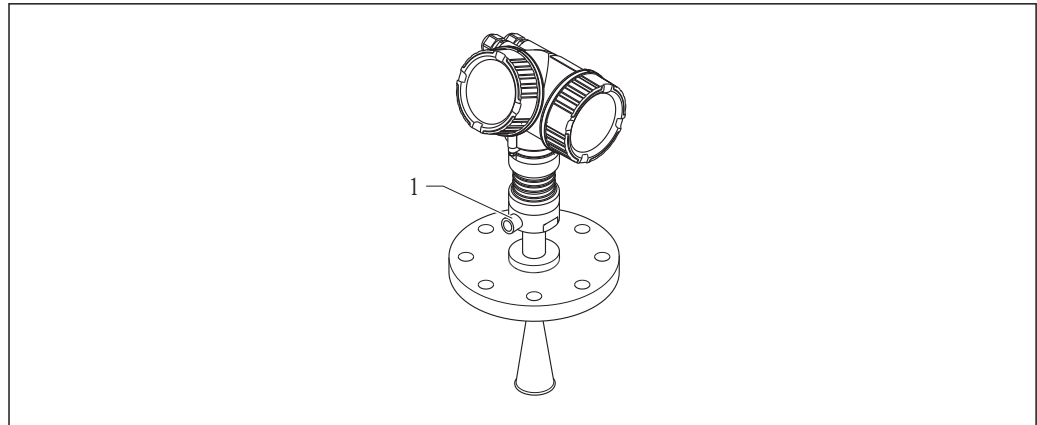

A0016932

17 Micropilot FMR57 with air purge connection

1 Air purge connection NPT $\frac{1}{4}$ or G $\frac{1}{4}$

Pressure range of the purge air

- **Pulsed operation:**
max. 6 bar (87 psi)
- **Permanent operation:**
200 to 500 mbar (3 to 7.25 psi)

i Make sure to use dry purge air.

i In general, air purging should only be used as much as necessary, since too much air purging may cause mechanical damage (abrasion).

Vessels with heat insulation

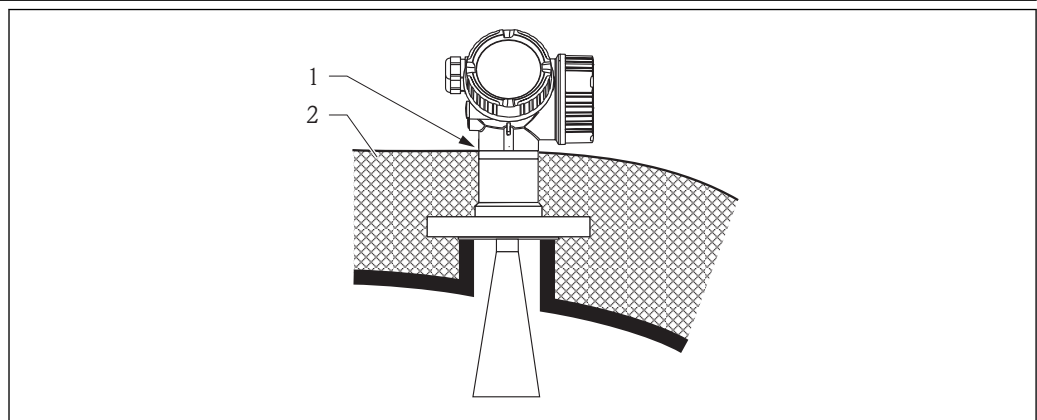

A0019142

If process temperatures are high, the device must be included in normal tank insulation to prevent the electronics heating up as a result of heat radiation or convection. The insulation may not exceed beyond the neck of the housing.

Environment



Ambient temperature range

Measuring device	-40 to +80 °C (-40 to +176 °F); -50 °C (-58 °F) with manufacturer declaration on request
Local display	-20 to +70 °C (-4 to +158 °F), the readability of the display may be impaired at temperatures outside the temperature range.

When operating the device in the open with strong sunlight:

- Mount the device in a shady position.
- Avoid direct sunlight, especially in warmer regions.
- Use a weather protection cover (see accessories).

Ambient temperature limits

 The following diagrams take into account only functional aspects. There may be further restrictions for certified device versions. Please refer to the separate Safety Instructions →  98.

With a temperature (T_p) at the process connection the admissible ambient temperature (T_a) is reduced according to the following diagram (temperature derating):

Information concerning the derating tables

Option	Meaning
A	2-wire; 4-20 mA HART
B	2-wire; 4-20 mA HART, switch output
C	2-wire; 4-20 mA HART, 4-20 mA
E	2-wire; FF, switch output
G	2-wire; PA, switch output
K	4-wire 90-253VAC; 4-20 mA HART
L	4-wire 10, 4-48VDC; 4-20 mA HART

FMR56 Housing: GT19 (Plastics PBT) Temperature unit: °C (°F)												
Power Supply; Output (Pos. 2 of the product structure)	P1		P2		P3		P4		P5		P6	
	T_p	T_a	T_p	T_a	T_p	T_a	T_p	T_a	T_p	T_a	T_p	T_a
A	-40 (-40)	80 (176)	80 (176)	80 (176)	80 (176)	80 (176)	80 (176)	-40 (-40)	-40 (-40)	-40 (-40)	-	-
B Switch output not used	-40 (-40)	76 (169)	76 (169)	76 (169)	80 (176)	75 (167)	80 (176)	-40 (-40)	-40 (-40)	-40 (-40)	-	-
B Switch output used	-40 (-40)	60 (140)	60 (140)	60 (140)	80 (176)	58 (136)	80 (176)	-40 (-40)	-40 (-40)	-40 (-40)	-	-
C Channel 2 not used	-40 (-40)	80 (176)	80 (176)	80 (176)	80 (176)	80 (176)	80 (176)	-40 (-40)	-40 (-40)	-40 (-40)	-	-
C Channel 2 used	-40 (-40)	74 (165)	74 (165)	74 (165)	80 (176)	73 (163)	80 (176)	-40 (-40)	-40 (-40)	-40 (-40)	-	-
E, G Switch output not used	-40 (-40)	79 (174)	79 (174)	79 (174)	80 (176)	79 (174)	80 (176)	-40 (-40)	-40 (-40)	-40 (-40)	-	-
E, G Switch output used	-40 (-40)	63 (145)	63 (145)	63 (145)	80 (176)	60 (140)	80 (176)	-40 (-40)	-40 (-40)	-40 (-40)	-	-

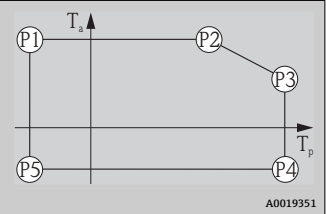

A0019351

FMR56
Housing: GT20 (Alu, coated)
Temperature unit: °C (°F)

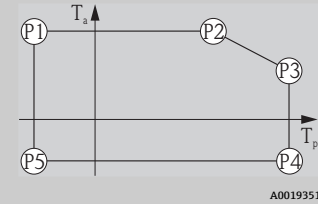

Power Supply; Output (Pos. 2 of the product structure)	P1		P2		P3		P4		P5		P6	
	T _p	T _a	T _p	T _a	T _p	T _a	T _p	T _a	T _p	T _a	T _p	T _a
A	-40 (-40)	80 (176)	80 (176)	80 (176)	80 (176)	80 (176)	80 (176)	-40 (-40)	-40 (-40)	-40 (-40)	-	-
B Switch output not used	-40 (-40)	80 (176)	80 (176)	80 (176)	80 (176)	80 (176)	80 (176)	-40 (-40)	-40 (-40)	-40 (-40)	-	-
B Switch output used	-40 (-40)	77 (171)	77 (171)	77 (171)	80 (176)	76 (169)	80 (176)	-40 (-40)	-40 (-40)	-40 (-40)	-	-
C Channel 2 not used	-40 (-40)	80 (176)	80 (176)	80 (176)	80 (176)	80 (176)	80 (176)	-40 (-40)	-40 (-40)	-40 (-40)	-	-
C Channel 2 used	-40 (-40)	79 (174)	79 (174)	79 (174)	80 (176)	79 (174)	80 (176)	-40 (-40)	-40 (-40)	-40 (-40)	-	-
E, G Switch output not used	-40 (-40)	80 (176)	80 (176)	80 (176)	80 (176)	80 (176)	80 (176)	-40 (-40)	-40 (-40)	-40 (-40)	-	-
E, G Switch output used	-40 (-40)	78 (172)	78 (172)	78 (172)	80 (176)	78 (172)	80 (176)	-40 (-40)	-40 (-40)	-40 (-40)	-	-
K, L	-40 (-40)	77 (171)	77 (171)	77 (171)	80 (176)	77 (171)	80 (176)	-40 (-40)	-40 (-40)	-40 (-40)	-	-

FMR57
Seal: Viton GLT
Housing: GT18 (316 L)
Temperature unit: °C (°F)

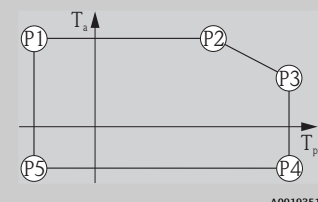

Power Supply; Output (Pos. 2 of the product structure)	P1		P2		P3		P4		P5		P6	
	T _p	T _a	T _p	T _a	T _p	T _a	T _p	T _a	T _p	T _a	T _p	T _a
A	-40 (-40)	81 (178)	81 (178)	81 (178)	200 (392)	67 (153)	200 (392)	-40 (-40)	-40 (-40)	-40 (-40)	-	-
B Switch output not used	-40 (-40)	82 (180)	82 (180)	82 (180)	200 (392)	67 (153)	200 (392)	-40 (-40)	-40 (-40)	-40 (-40)	-	-
B Switch output used	-40 (-40)	77 (171)	77 (171)	77 (171)	200 (392)	62 (144)	200 (392)	-40 (-40)	-40 (-40)	-40 (-40)	-	-
C Channel 2 not used	-40 (-40)	82 (180)	82 (180)	82 (180)	200 (392)	68 (154)	200 (392)	-40 (-40)	-40 (-40)	-40 (-40)	-	-
C Channel 2 used	-40 (-40)	79 (174)	79 (174)	79 (174)	200 (392)	64 (147)	200 (392)	-40 (-40)	-40 (-40)	-40 (-40)	-	-
E, G Switch output not used	-40 (-40)	83 (181)	83 (181)	83 (181)	200 (392)	68 (154)	200 (392)	-40 (-40)	-40 (-40)	-40 (-40)	-	-
E, G Switch output used	-40 (-40)	78 (172)	78 (172)	78 (172)	200 (392)	63 (145)	200 (392)	-40 (-40)	-40 (-40)	-40 (-40)	-	-
K, L	-40 (-40)	77 (171)	77 (171)	77 (171)	200 (392)	62 (144)	200 (392)	-40 (-40)	-40 (-40)	-40 (-40)	-	-

FMR57
 Seal: Viton GLT
 Housing: GT19 (Plastics PBT)
 Temperature unit: °C (°F)

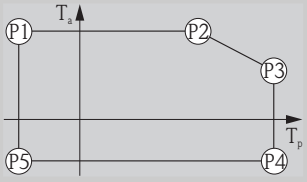

Power Supply; Output (Pos. 2 of the product structure)	P1		P2		P3		P4		P5		P6	
	T _p	T _a	T _p	T _a	T _p	T _a	T _p	T _a	T _p	T _a	T _p	T _a
A	-40 (-40)	80 (176)	80 (176)	80 (176)	200 (392)	53 (127)	200 (392)	-40 (-40)	-40 (-40)	-40 (-40)	-	-
B Switch output not used	-40 (-40)	76 (169)	76 (169)	76 (169)	200 (392)	53 (127)	200 (392)	-40 (-40)	-40 (-40)	-40 (-40)	-	-
B Switch output used	-40 (-40)	60 (140)	60 (140)	60 (140)	200 (392)	37 (99)	200 (392)	-40 (-40)	-40 (-40)	-40 (-40)	-	-
C Channel 2 not used	-40 (-40)	82 (180)	82 (180)	82 (180)	200 (392)	53 (127)	200 (392)	-40 (-40)	-40 (-40)	-40 (-40)	-	-
C Channel 2 used	-40 (-40)	74 (165)	74 (165)	74 (165)	200 (392)	53 (127)	200 (392)	-40 (-40)	-40 (-40)	-40 (-40)	-	-
E, G Switch output not used)	-40 (-40)	79 (174)	79 (174)	79 (174)	200 (392)	53 (127)	200 (392)	-40 (-40)	-40 (-40)	-40 (-40)	-	-
E, G Switch output used	-40 (-40)	63 (145)	63 (145)	63 (145)	200 (392)	40 (104)	200 (392)	-40 (-40)	-40 (-40)	-40 (-40)	-	-

FMR57
 Seal: Viton GLT
 Housing: GT20 (Alu, coated)
 Temperature unit: °C (°F)

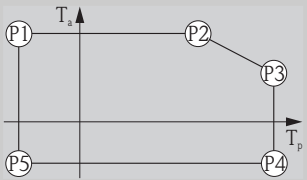

Power Supply; Output (Pos. 2 of the product structure)	P1		P2		P3		P4		P5		P6	
	T _p	T _a	T _p	T _a	T _p	T _a	T _p	T _a	T _p	T _a	T _p	T _a
A	-40 (-40)	81 (178)	81 (178)	81 (178)	200 (392)	70 (158)	200 (392)	-40 (-40)	-40 (-40)	-40 (-40)	-	-
B Switch output not used	-40 (-40)	82 (180)	82 (180)	82 (180)	200 (392)	70 (158)	200 (392)	-40 (-40)	-40 (-40)	-40 (-40)	-	-
B Switch output used	-40 (-40)	77 (171)	77 (171)	77 (171)	200 (392)	65 (149)	200 (392)	-40 (-40)	-40 (-40)	-40 (-40)	-	-
C Channel 2 not used	-40 (-40)	82 (180)	82 (180)	82 (180)	200 (392)	71 (160)	200 (392)	-40 (-40)	-40 (-40)	-40 (-40)	-	-
C Channel 2 used	-40 (-40)	79 (174)	79 (174)	79 (174)	200 (392)	67 (153)	200 (392)	-40 (-40)	-40 (-40)	-40 (-40)	-	-
E, G Switch output not used	-40 (-40)	83 (181)	83 (181)	83 (181)	200 (392)	71 (160)	200 (392)	-40 (-40)	-40 (-40)	-40 (-40)	-	-
E, G Schaltausgang verwende)	-40 (-40)	78 (172)	78 (172)	78 (172)	200 (392)	66 (151)	200 (392)	-40 (-40)	-40 (-40)	-40 (-40)	-	-
K, L	-40 (-40)	77 (171)	77 (171)	77 (171)	200 (392)	66 (151)	200 (392)	-40 (-40)	-40 (-40)	-40 (-40)	-	-

FMR57
Seal: Graphite
Housing: GT18 (316 L)
Temperature unit: °C (°F)

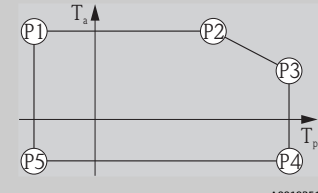

Power Supply; Output (Pos. 2 of the product structure)	P1		P2		P3		P4		P5		P6	
	T _p	T _a	T _p	T _a	T _p	T _a	T _p	T _a	T _p	T _a	T _p	T _a
A	-40 (-40)	81 (178)	81 (178)	81 (178)	400 (752)	51 (124)	400 (752)	-40 (-40)	-40 (-40)	-40 (-40)	-	-
B Switch output not used	-40 (-40)	82 (180)	82 (180)	82 (180)	400 (752)	51 (124)	400 (752)	-40 (-40)	-40 (-40)	-40 (-40)	-	-
B Switch output used	-40 (-40)	77 (171)	77 (171)	77 (171)	400 (752)	47 (117)	400 (752)	-40 (-40)	-40 (-40)	-40 (-40)	-	-
C Channel 2 not used	-40 (-40)	82 (180)	82 (180)	82 (180)	400 (752)	51 (124)	400 (752)	-40 (-40)	-40 (-40)	-40 (-40)	-	-
C Channel 2 used	-40 (-40)	79 (174)	79 (174)	79 (174)	400 (752)	49 (120)	400 (752)	-40 (-40)	-40 (-40)	-40 (-40)	-	-
E, G Switch output not used	-40 (-40)	83 (181)	83 (181)	83 (181)	400 (752)	51 (124)	400 (752)	-40 (-40)	-40 (-40)	-40 (-40)	-	-
E, G Switch output used	-40 (-40)	78 (172)	78 (172)	78 (172)	400 (752)	49 (120)	400 (752)	-40 (-40)	-40 (-40)	-40 (-40)	-	-
K, L	-40 (-40)	77 (171)	77 (171)	77 (171)	400 (752)	48 (118)	400 (752)	-40 (-40)	-40 (-40)	-40 (-40)	-	-

FMR57
Seal: Graphite
Housing: GT19 (Plastics PBT)
Temperature unit: °C (°F)

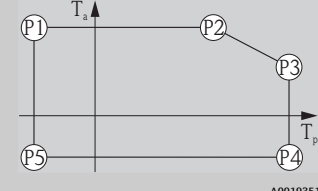

Power Supply; Output (Pos. 2 of the product structure)	P1		P2		P3		P4		P5		P6	
	T _p	T _a	T _p	T _a	T _p	T _a	T _p	T _a	T _p	T _a	T _p	T _a
A	-40 (-40)	80 (176)	80 (176)	80 (176)	400 (752)	15 (59)	400 (752)	-40 (-40)	-40 (-40)	-40 (-40)	-	-
B Switch output not used	-40 (-40)	76 (169)	76 (169)	76 (169)	400 (752)	15 (59)	400 (752)	-40 (-40)	-40 (-40)	-40 (-40)	-	-
B Switch output used	-40 (-40)	60 (140)	60 (140)	60 (140)	400 (752)	15 (59)	400 (752)	-40 (-40)	-40 (-40)	-40 (-40)	-	-
C Channel 2 not used	-40 (-40)	82 (180)	82 (180)	82 (180)	400 (752)	15 (59)	400 (752)	-40 (-40)	-40 (-40)	-40 (-40)	-	-
C Channel 2 used	-40 (-40)	74 (165)	74 (165)	74 (165)	400 (752)	15 (59)	400 (752)	-40 (-40)	-40 (-40)	-40 (-40)	-	-
E, G Switch output not used	-40 (-40)	79 (174)	79 (174)	79 (174)	400 (752)	15 (59)	400 (752)	-40 (-40)	-40 (-40)	-40 (-40)	-	-
E, G Switch output used	-40 (-40)	63 (145)	63 (145)	63 (145)	400 (752)	15 (59)	400 (752)	-40 (-40)	-40 (-40)	-40 (-40)	-	-

FMR57 Seal: Graphite Housing: GT20 (Alu, coated) Temperature unit: °C (°F)												
Power Supply; Output (Pos. 2 of the product structure)	P1		P2		P3		P4		P5		P6	
	T _p	T _a	T _p	T _a	T _p	T _a	T _p	T _a	T _p	T _a	T _p	T _a
A	-40 (-40)	81 (178)	81 (178)	81 (178)	400 (752)	58 (136)	400 (752)	-40 (-40)	-40 (-40)	-40 (-40)	-	-
B Switch output not used	-40 (-40)	82 (180)	82 (180)	82 (180)	400 (752)	59 (138)	400 (752)	-40 (-40)	-40 (-40)	-40 (-40)	-	-
B Switch output used	-40 (-40)	77 (171)	77 (171)	77 (171)	400 (752)	53 (127)	400 (752)	-40 (-40)	-40 (-40)	-40 (-40)	-	-
C Channel 2 not used	-40 (-40)	82 (180)	82 (180)	82 (180)	400 (752)	59 (138)	400 (752)	-40 (-40)	-40 (-40)	-40 (-40)	-	-
C Channel 2 used	-40 (-40)	79 (174)	79 (174)	79 (174)	400 (752)	56 (133)	400 (752)	-40 (-40)	-40 (-40)	-40 (-40)	-	-
E, G Switch output not used	-40 (-40)	83 (181)	83 (181)	83 (181)	400 (752)	59 (138)	400 (752)	-40 (-40)	-40 (-40)	-40 (-40)	-	-
E, G Switch output used	-40 (-40)	78 (172)	78 (172)	78 (172)	400 (752)	55 (131)	400 (752)	-40 (-40)	-40 (-40)	-40 (-40)	-	-
K, L	-40 (-40)	77 (171)	77 (171)	77 (171)	400 (752)	54 (129)	400 (752)	-40 (-40)	-40 (-40)	-40 (-40)	-	-

Storage temperature -40 to +80 °C (-40 to +176 °F)
 -50 °C (-58 °F) with manufacturer declaration on request

Climate class DIN EN 60068-2-38 (test Z/AD)

Altitude according to IEC61010-1 Ed.3

- Generally up to 2 000 m (6 600 ft) above MSL.
- Above 2 000 m (6 600 ft) if the following conditions are met:
 - Ordering feature 020 "Power supply; Output" = A, B, C, E or G (2-wire versions)
 - Supply voltage U < 35 V
 - Supply voltage of overvoltage category 1

Degree of protection

- With closed housing tested according to:
 - IP68, NEMA6P (24 h at 1.83 m under water surface)
 - For plastic housing with transparent cover (display module): IP68 (24 h at 1.00 m under water surface)³⁾
 - IP66, NEMA4X
- With open housing: IP20, NEMA1
- Display module: IP22, NEMA2

Degree of protection IP68 NEMA6P applies for M12 PROFIBUS PA plugs only when the PROFIBUS cable is plugged in and is also rated IP68 NEMA6P.

Vibration resistance DIN EN 60068-2-64 / IEC 60068-2-64: 20 to 2 000 Hz, 1 (m/s²)/Hz

Cleaning the antenna The antenna can get contaminated, depending on the application. The emission and reception of microwaves can thus eventually be hindered. The degree of contamination leading to an error depends on the medium and the reflectivity, mainly determined by the dielectric constant ε_r.

If the medium tends to cause contamination and deposits, cleaning on a regular basis is recommended. In the case of FRM57, the integrated air purge connection can be used for this

3) This restriction is valid if the following options of the product structure have been selected at the same time: 030 ("Display, Operation") = C ("SD02") or E ("SD03"); 040 ("Housing") = A ("GT19").

→ 41. Care has to be taken not to damage the antenna in the process of a mechanical or hose-down cleaning. The material compatibility has to be considered if cleaning agents are used! The maximum permitted temperature at the flange should not be exceeded.

Electromagnetic compatibility (EMC)

Electromagnetic compatibility to all relevant requirements of the EN 61326- series and NAMUR recommendation EMC (NE21). For details see declaration of conformity. ⁴⁾.

If only the analogue signal is used, unshielded interconnection lines are sufficient for the installation. In case of using the digital signal (HART/ PA/ FF) use shielded interconnection lines.

Max. fluctuations during EMC- tests: < 0.5 % of the span. As an exception to this, the maximum fluctuations may amount to 2 % of the span for devices with plastic housing and see-through lid (integrated display SD02 or SD03) if strong electromagnetic interferences in the frequency range of 1 to 2 GHz are present.

4) Can be downloaded from www.endress.com.

Process

Process temperature, Process pressure



The specified pressure range may be reduced due to the selected process connection. The pressure rating (PN) specified on the flanges refers to a reference temperature of 20 °C, for ASME flanges 100 °F. Pay attention to pressure-temperature dependencies.

Please refer to the following standards for the pressure values permitted for higher temperatures:

- EN 1092-1: 2001 Tab. 18

With regard to their temperature stability properties, the materials 1.4435 and 1.4404 are grouped under 13E0 in EN 1092-1 Tab. 18. The chemical composition of the two materials can be identical.

- ASME B 16.5a - 1998 Tab. 2-2.2 F316
- ASME B 16.5a - 1998 Tab. 2.3.8 N10276
- JIS B 2220

FMR56

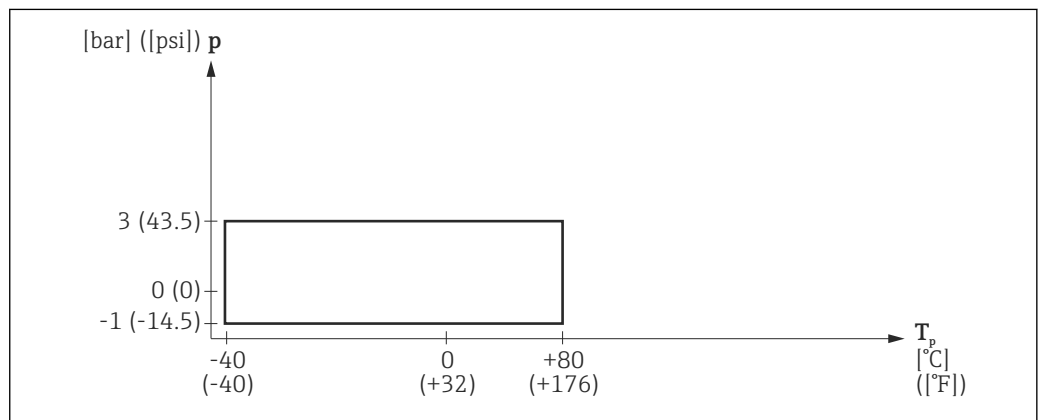

A0023253-EN

18 FMR56: Admissible range of process temperature and process pressure

Device version	Admissible process temperature	Admissible process pressure
All versions	-40 to +80 °C (-40 to +176 °F)	$p_{rel} = -1$ to 3 bar (-14.5 to 43.5 psi) $p_{abs} < 4$ bar (58 psi) ¹⁾

1) For devices with CRN approval the pressure range may be reduced → 79

FMR57

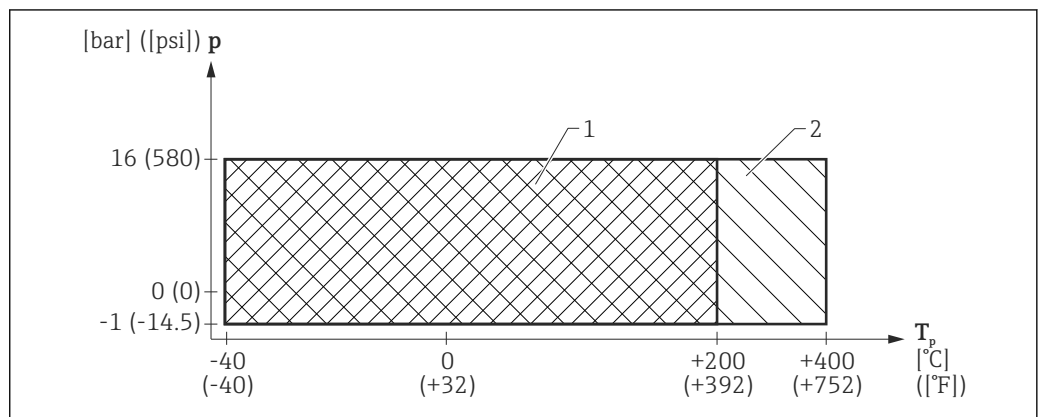

A0023253-EN

19 FMR57: Admissible range of process temperature and process pressure

- 1 Seal: Viton GLT (Feature 090 "Seal", Option A6)
- 2 Seal: Graphite (Feature 090 "Seal", Option D4)

Feature 090 "Seal"	Admissible process temperature	Admissible process pressure
A6: Viton GLT	-40 to +200 °C (-40 to +392 °F)	p _{rel} = -1 to 16 bar (-14.5 to 232 psi)
D4: Graphite	-40 to +400 °C (-40 to +752 °F)	

Dielectric constant

- **For liquids**

- $\epsilon_r \geq 1.9$ in free-field applications
- $\epsilon_r \geq 1.4$ in stilling well

- **For bulk solids**

$$\epsilon_r \geq 1.6$$



For dielectric constants (DC values) of many media commonly used in various industries refer to:

- the Endress+Hauser DC manual (CP01076F)
- the Endress+Hauser "DC Values App" (available for Android and iOS)

Mechanical construction

Dimensions

Dimensions of the electronics housing

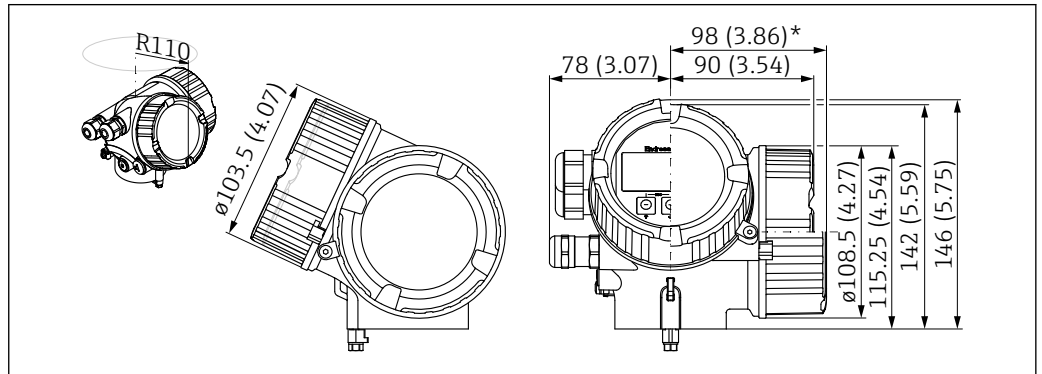

A0011666

20 Housing GT18 (316L); Dimensions in mm (in)

*for devices with integrated overvoltage protection.

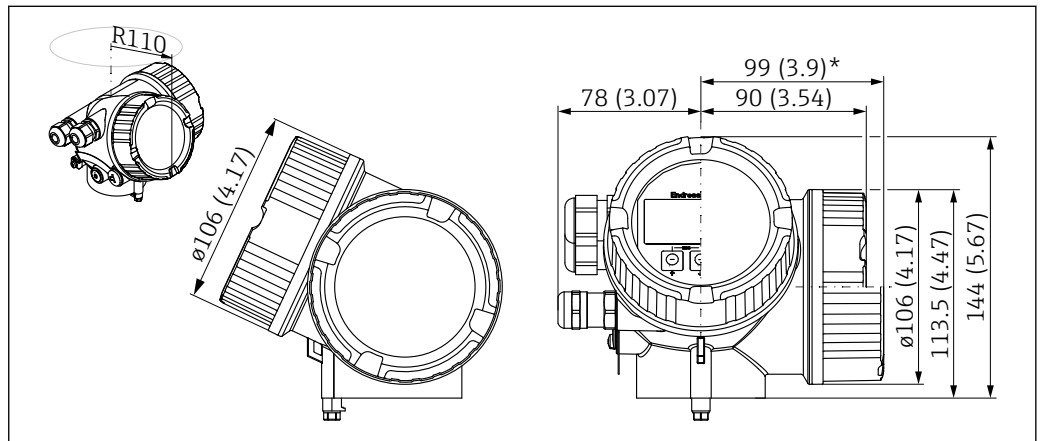

A0011346

21 Housing GT19 (Plastics PBT); Dimensions in mm (in)

*for devices with integrated overvoltage protection.

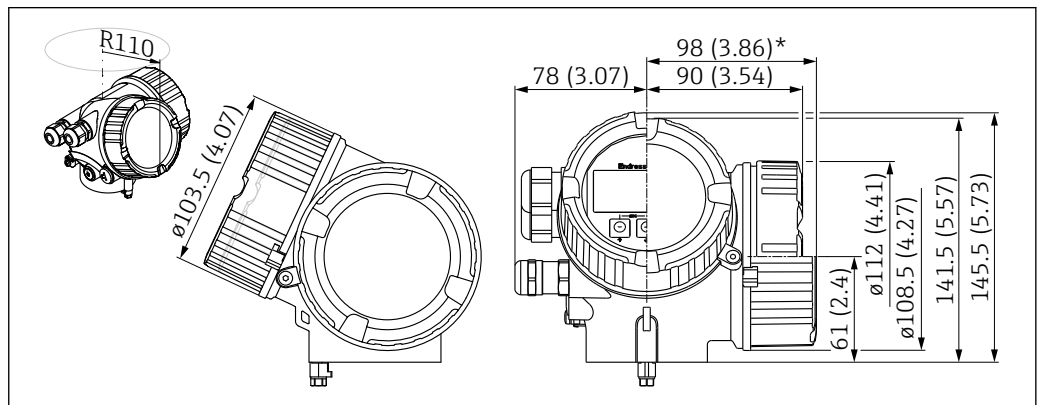

A0020751

22 Housing GT20 (Alu coated); Dimensions in mm (in)

*for devices with integrated overvoltage protection.

FMR56 with mounting bracket or customer side connection

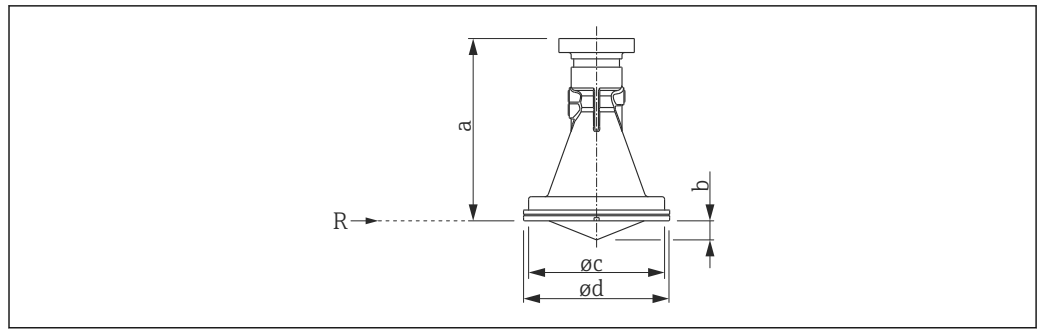

A0017747

23 FMR56 without process connection; dimensions: mm (in)

R Reference point of the measurement

	Feature 100 "Process connection"	
	<ul style="list-style-type: none"> ▪ UAE: Mounting bracket ▪ XRO: Customer side connection 	
	Feature 070 "Antenna" BN: Horn 80mm/3"	Feature 070 "Antenna" BR: Horn 100mm/4"
a	137.9 mm (5.43 in)	150.5 mm (5.93 in)
b	15 mm (0.59 in)	20 mm (0.79 in)
øc	107 mm (4.21 in)	127 mm (5 in)
ød	115 mm (4.53 in)	135 mm (5.31 in)

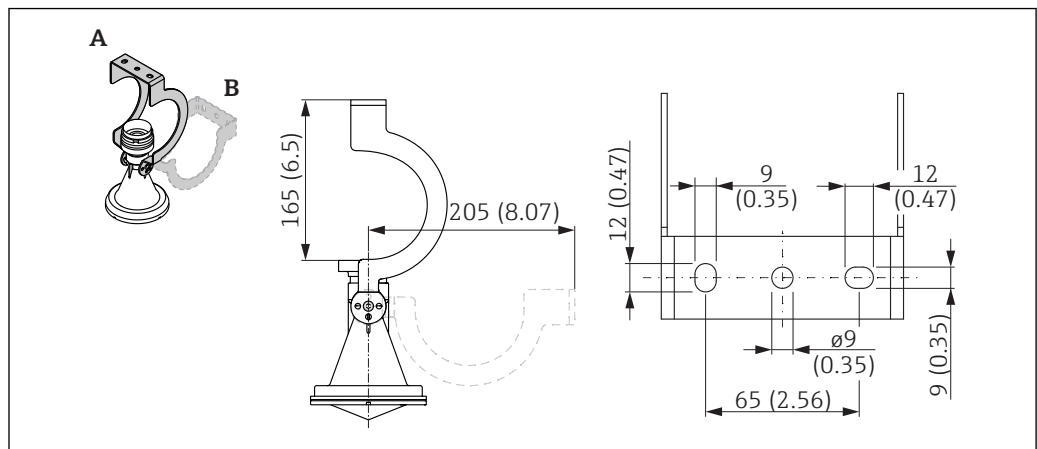

A0017746

24 Mounting bracket for FMR50/FMR56; dimensions: mm (in)

A Mounting bracket aligned for roof mounting

B Mounting bracket aligned for wall mounting

FMR56 with slip-on flange 3"/DN80

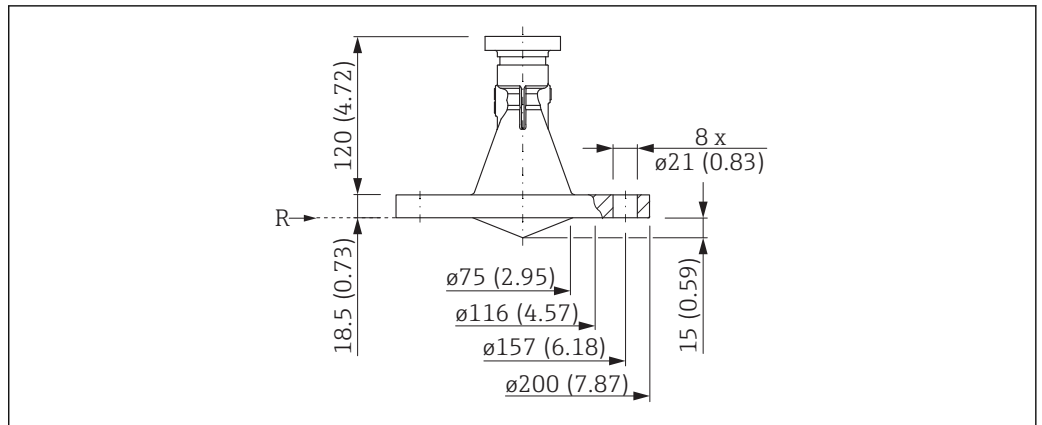

A0023377

25 FMR56 with slip-on flange 3"/DN80; dimensions: mm (in)

R Reference point of the measurement

Valid for the following device versions

- **Feature 100 "Process connection"**
XWG: UNI slip-on flange 3"/DN80, PP
- **Feature 070 "Antenna"**
BN: Horn 80mm/3", PP cladded

- i** The UNI slip-on flange is suitable for:
- ASME: NPS 3" Cl.150
 - EN: DN80 PN16
 - JIS: 10K 80

FMR56 with slip-on flange 4"/DN100

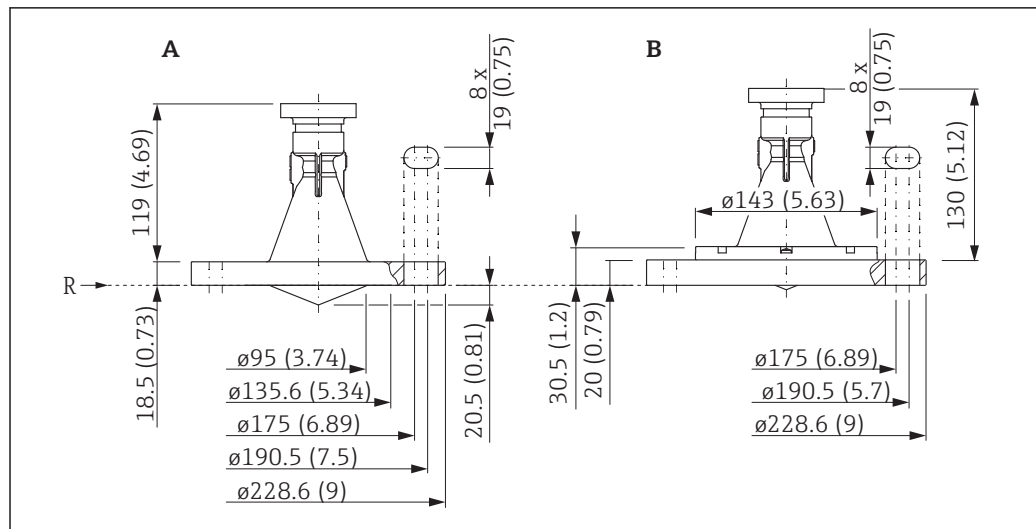

A0023379

26 FMR56 with slip-on flange 4"/DN100; dimensions: mm (in)

A Horn antenna 100mm/4" (without adapter ring)

B Horn antenna 80mm/3" (with adapter ring)

R Reference point of the measurement

Valid for the following device versions

- Feature 100 "Process connection":

XZG: UNI slip-on flange 4"/DN100

- Feature 070 "Antenna":

- BR: Horn 100mm/4", PP cladded (diagram A)

- BN: Horn 80mm/3", PP cladded (diagram B)



The UNI slip-on flange is suitable for:

- ASME: NPS 4" Cl.150
- EN: DN100 PN16
- JIS: 10K 100

FMR56 with slip-on flange 6"/DN150

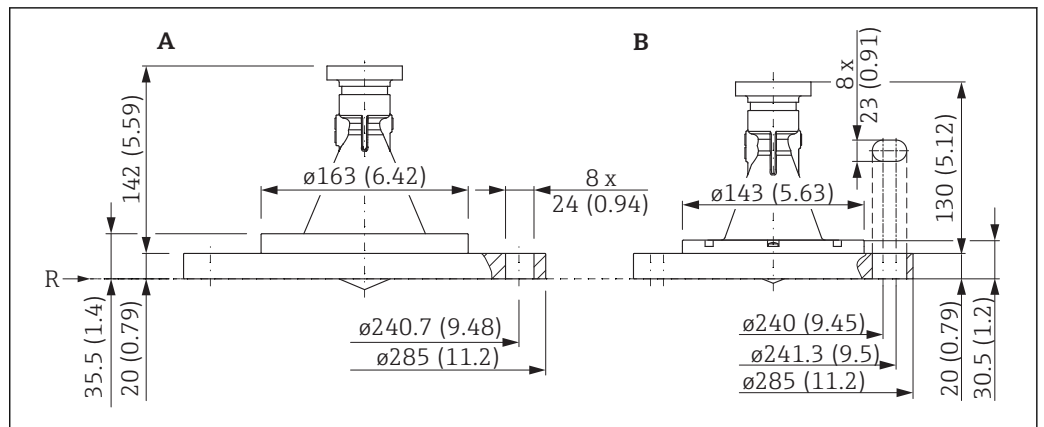

A0023380

27 FMR56 with slip-on flange 6"/DN150; dimensions: mm (in)

- A Horn antenna 100mm/4"
- B Horn antenna 80mm/3"
- R Reference point of the measurement

Valid for the following device versions

- **Feature 100 "Process connection":**
XOG: UNI slip-on flange 6"/DN150, PP
- **Feature 070 "Antenna":**
 - BR: Horn 100mm/4", PP clad (diagram A)
 - BN: Horn 80mm/3", PP clad (diagram B)

- **i** The UNI slip-on flange is suitable for:
 - ASME: NPS 6" Cl.150
 - EN: DN150 PN16
 - JIS: 10K 150

FMR57 with horn antenna - standard version

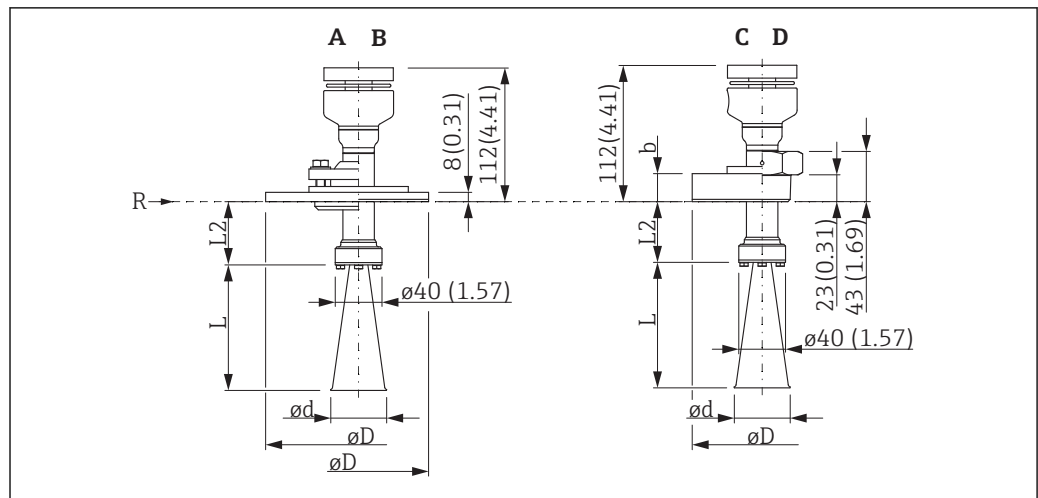

A0023392

28 FMR57 with horn antenna - standard version; dimensions: mm(in)

- A Process connection: Alignment device with UNI flange
- B Process connection: UNI flange
- C Process connection: flange
- D Process connection: Thread MNPT1-1/2 or R1-1/2
- R Reference point of the measurement

Valid for the following device versions

- Feature 070 "Antenna"
 - BC: Horn 80mm/3"
 - BD: Horn 100mm/4"
- Feature 090 "Seal"
 - A6: Viton GLT, -40...200°C/-40...392°F

Dimensions of the antenna

Dimension	Feature 070 "Antenna"	
	BC: Horn 80mm/3"	BD: Horn 100mm/4"
L	211 mm (8.37 in)	430 mm (16.9 in)
ød	ø75 mm (2.95 in)	ø95 mm (3.74 in)
L2	50 mm (1.97 in)	50 mm (1.97 in)
	for version with 250 mm (10 in) antenna extension ¹⁾ :	
	300 mm (11.8 in)	300 mm (11.8 in)
L2	for version with 450 mm (18 in) antenna extension:	
	500 mm (19.7 in)	500 mm (19.7 in)

1) Product structure: Feature 610: "Accessory Mounted"

i Dimensions of the flange (b, øD): → 59

FMR57 with horn antenna - high temperature version

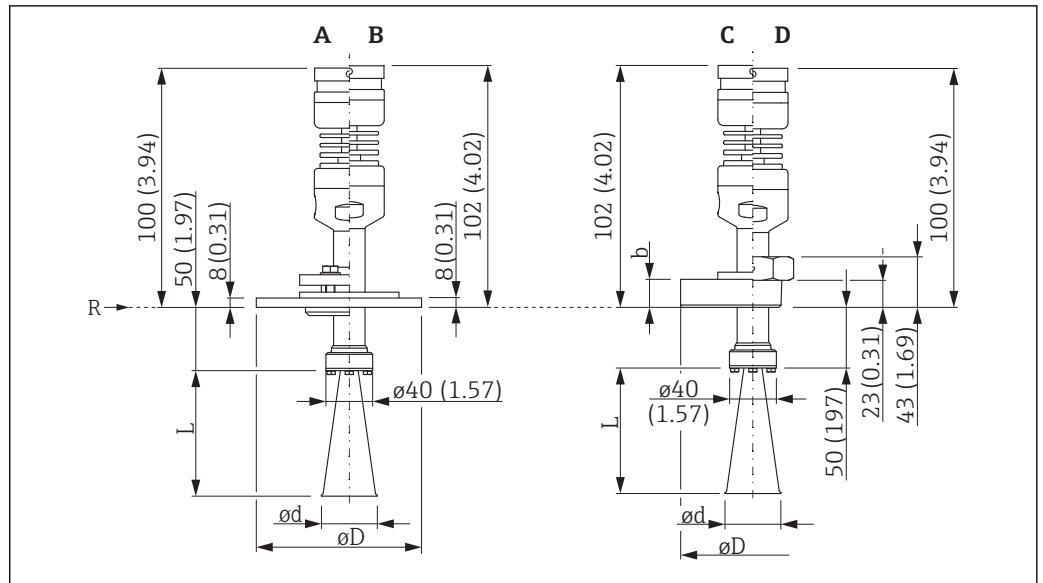

29 FMR57 with horn antenna - high temperature version; dimensions: mm(in)

- A Process connection: Alignment unit with UNI flange
- B Process connection: UNI flange
- C Process connection: Flange
- D Process connection: Thread MNPT1-1/2 or R1-1/2
- R Reference point of the measurement

Valid for the following device versions

- **Feature 070 "Antenna"**
 - BC: Horn 80mm/3"
 - BD: Horn 100mm/4"
- **Feature 090 "Seal"**
 - D4: Graphite, -40...400°C/-40...752°F

Horn antenna

Dimension	Feature 070 "Antenna"	
	BC: Horn 80mm/3"	BD: Horn 100mm/4"
L	211 mm (8.37 in)	430 mm (16.9 in)
ød	ø75 mm (2.95 in)	ø95 mm (3.74 in)

Dimensions for the flanges (b, øD): → 59

FMR57 with parabolic antenna

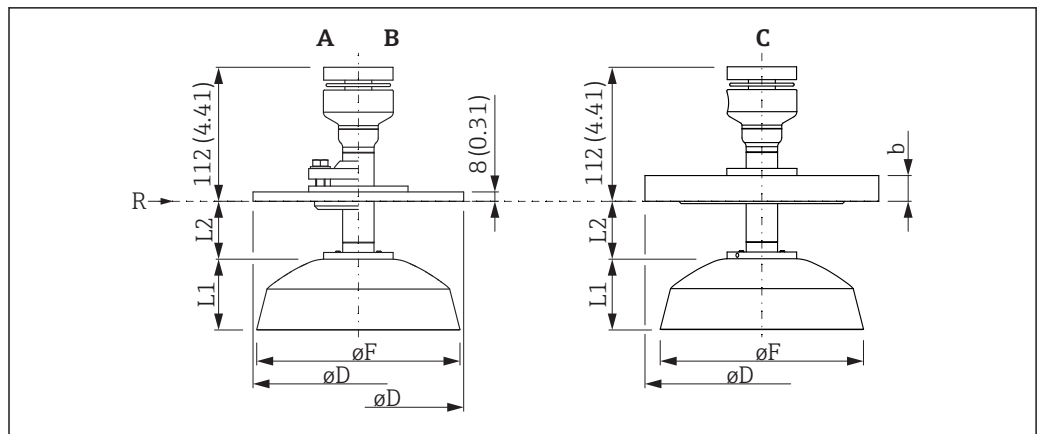

A0023393

30 FMR57 with parabolic antenna; dimensions: mm(in)

- A Process connection: Alignment unit with UNI flange
- B Process connection: UNI flange
- C Process connection: Flange
- R Reference point of the measurement

Dimension	Feature 070 "Antenna"	
	FA: Parabolic 200 mm/8"	FB: Parabolic 250 mm/10"
L1	61 mm (2.4 in)	89 mm (3.5 in)
øF	ø173 mm (6.81 in)	ø236 mm (9.29 in)
L2	50 mm (1.97 in)	37 mm (1.46 in)
	for version with 250 mm (10 in) antenna extension ¹⁾ :	
	300 mm (11.8 in)	287 mm (11.3 in)
L2	for version with 450 mm (18 in) antenna extension ¹⁾ :	
	500 mm (19.7 in)	487 mm (19.2 in)

1) Product structure: Feature 610: "Accessory Mounted"

i Dimensions of the flanges (b, øD): → 59

FMR57: Dimensions of the flanges

Flanges according to EN1092-1 (suitable for DIN2527)

Pressure rating ¹⁾	Dimension	Nominal diameter ¹⁾	
		DN80	DN100
PN10/16	b	20 mm (0.79 in)	20 mm (0.79 in)
	φD	φ200 mm (7.87 in)	φ220 mm (8.66 in)

1) Feature 100 of the product structure

Flanges according to ASME B16.5

Pressure rating ¹⁾	Dimension	Nominal diameter ¹⁾	
		3"	4"
Cl. 150	b	22.3 mm (0.88 in)	22.3 mm (0.88 in)
	φD	φ190 mm (7.5 in)	φ230 mm (9 in)

1) Feature 100 of the product structure

Flanges according to JIS B2220

Pressure rating ¹⁾	Dimension	Nominal diameter ¹⁾	
		DN80	DN100
10 K	b	18 mm (0.71 in)	18 mm (0.71 in)
	φD	φ185 mm (7.28 in)	φ210 mm (8.27 in)

1) Feature 100 of the product structure

Endress+Hauser UNI flanges

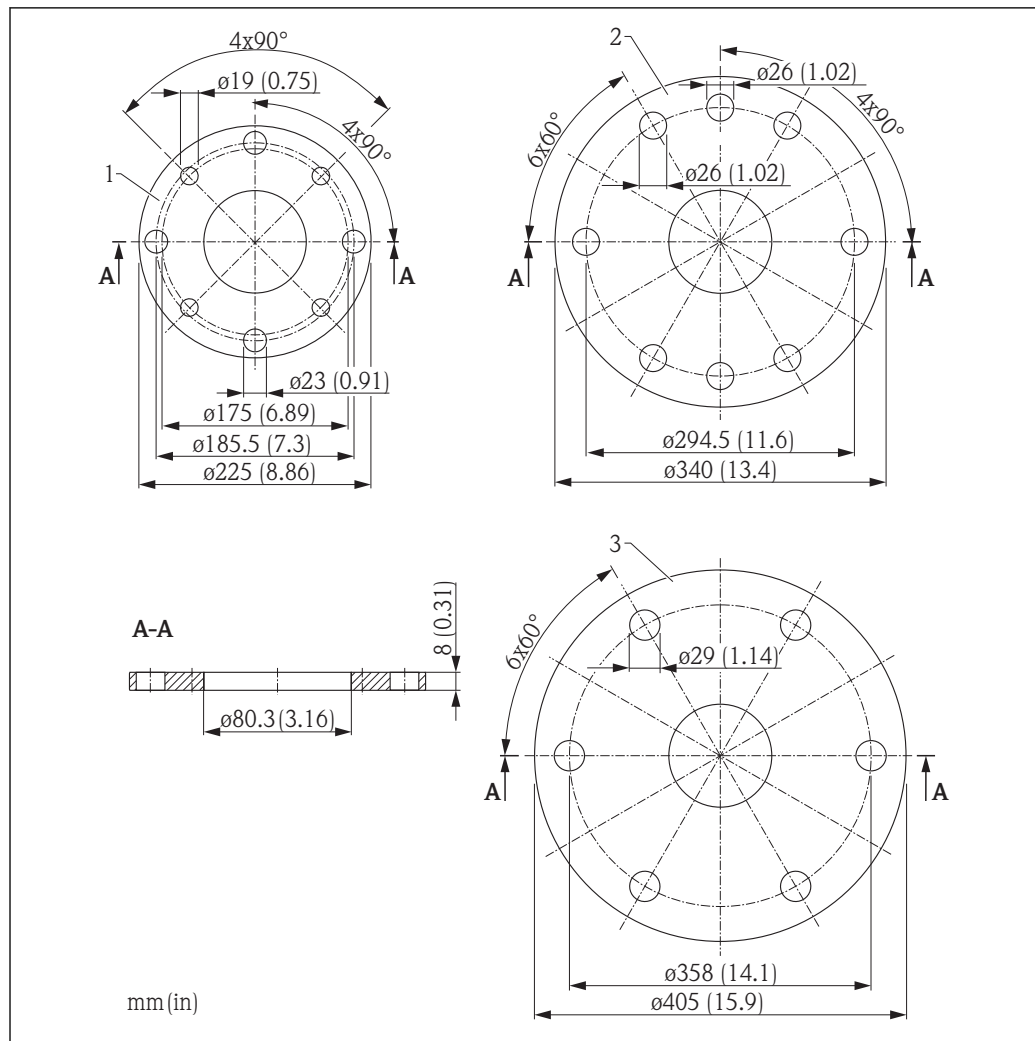

A0018947

Pos.	Feature 100: Process connection	Suitable for	Material
1:	XCJ: Alignment device, UNI 4"/DN100	<ul style="list-style-type: none"> ▪ 4" 150lbs ▪ DN100 PN16/PN25/PN40 ▪ 10K/16K/20K 100 	316L (1.4404)
2:	<ul style="list-style-type: none"> ▪ XEJ: Alignment device, UNI 8"/DN200 ▪ X3J: UNI flange DN200/8" 	<ul style="list-style-type: none"> ▪ 8" 150lbs ▪ DN200 PN16 ▪ 10K 200 	316L (1.4404)
3:	<ul style="list-style-type: none"> ▪ XFJ: Alignment device, UNI 10"/DN250 ▪ X5J: UNI flange DN250/10" 	<ul style="list-style-type: none"> ▪ 10" 150lbs ▪ DN250 PN16 ▪ 10K 250 	316L (1.4404)

i The number of bolts is reduced in some cases. To match different standards the bores are enlarged. Therefore the bolts should be aligned centrally to the counter flange before tightening.

Alignment device with Endress+Hauser UNI flange

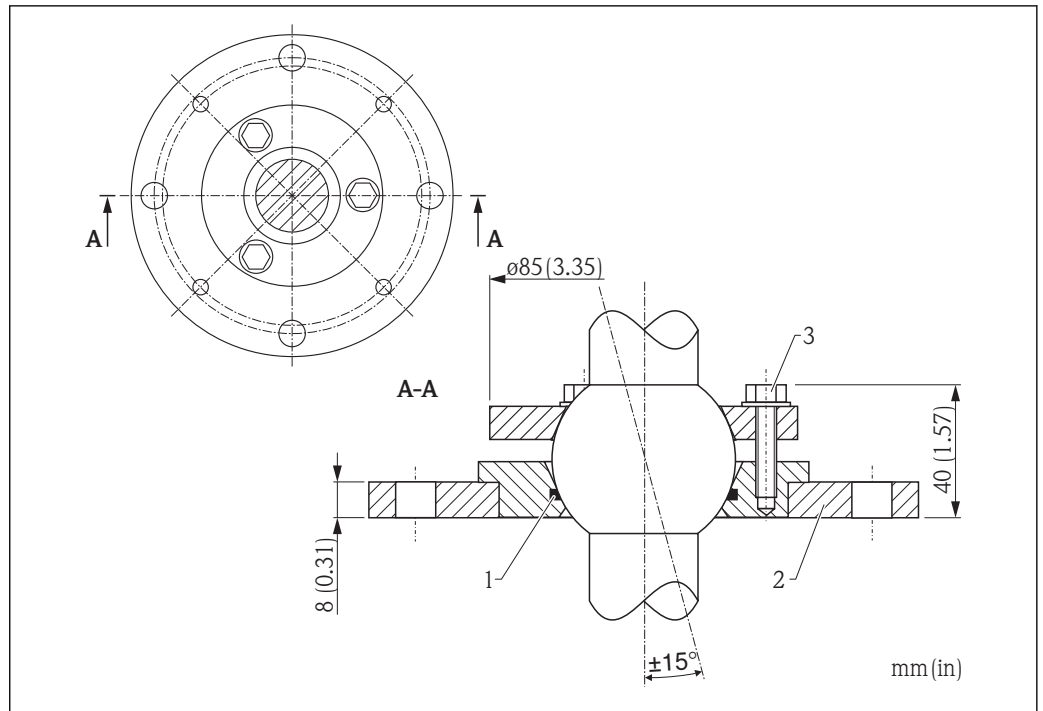

A0018948

- 1 Viton seal
- 2 Endress+Hauser UNI flange DN100/200/250
- 3 Clamping screws 3 x M8, (displaced by an angle of 120° from each other)

i For the high temperature version of the FMR57 (sales option 090: "Seal", option D4 "Graphite, -40...400°C / -40...752°F"), there is no Viton seal (1) at the alignment device.

Weight

Housing

Part	Weight
Housing GT18 - stainless steel	approx. 4.5 kg (9.9 lb)
Housing GT19 - plastic	approx. 1.2 kg (2.7 lb)
Housing GT20 - aluminium	approx. 1.9 kg (4.2 lb)

Antenna and process connection

Device	Weight of antenna and process connection
FMR56	max. 1.5 kg (3.3 lb) + weight of flange ¹⁾
FMR57	max. 5.5 kg (12.1 lb) + weight of flange ¹⁾

1) For the weight of the flange refer to Technical Information TI00426F.

**Materials: GT18 housing
(stainless steel, corrosion-
resistant)**

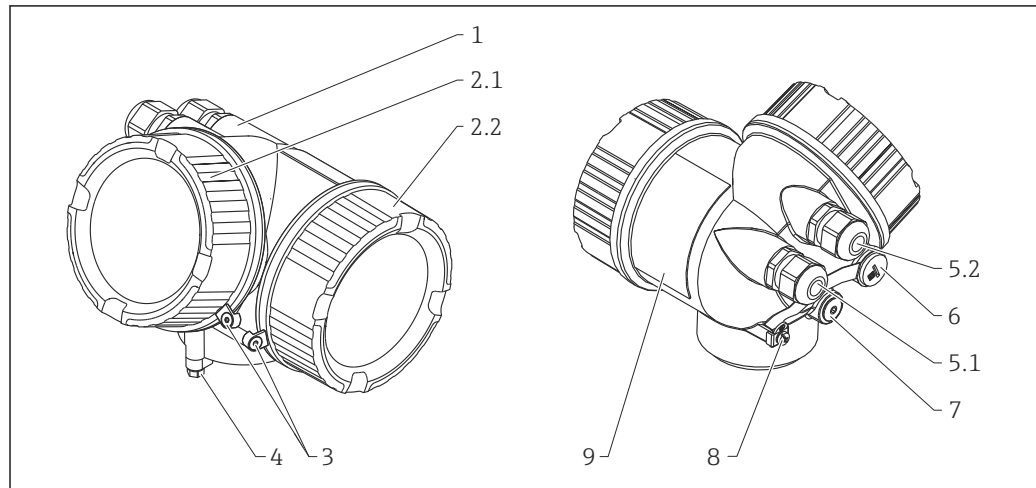

A0013788

No.	Part	Material
1	Housing	CF3M similar to 316L/1.4404
2.1	Cover of the electronics compartment	<ul style="list-style-type: none"> ▪ Cover: CF3M (similar to 316L/1.4404) ▪ Window: glass ▪ Cover seal: NBR ▪ Seal of the window: NBR ▪ Thread-coating: Graphite-based lubricant varnish
2.2	Cover of the terminal compartment	<ul style="list-style-type: none"> ▪ Cover: CF3M (similar to 316L/1.4404) ▪ Cover seal: NBR ▪ Thread-coating: Graphite-based lubricant varnish
3	Cover lock	<ul style="list-style-type: none"> ▪ Screw: A4 ▪ Clamp: 316L (1.4404)
4	Lock at the housing neck	<ul style="list-style-type: none"> ▪ Screw: A4-70 ▪ Clamp: 316L (1.4404)
5.1	Dummy plug, cable gland, adapter or plug (depending on the device version)	<ul style="list-style-type: none"> ▪ Dummy plug, depending on the device version: <ul style="list-style-type: none"> – PE – PBT-GF ▪ Cable gland: 316L (1.4404) or nickel-plated brass ▪ Adapter: 316L (1.4404/1.4435) ▪ Seal: EPDM ▪ M12 plug: Nickel-plated brass ¹⁾ ▪ 7/8" plug: 316 (1.4401) ²⁾
5.2	Dummy plug, cable gland or adapter (depending on the device version)	<ul style="list-style-type: none"> ▪ Dummy plug: 316L (1.4404) ▪ Cable gland: 316L (1.4404) or nickel-plated brass ▪ Adapter: 316L (1.4404/1.4435) ▪ Seal: EPDM
6	Dummy plug or M12 socket (depending on the device version)	<ul style="list-style-type: none"> ▪ Dummy plug: 316L (1.4404) ▪ M12 socket: 316L (1.4404)
7	Pressure relief stopper	316L (1.4404)
8	Ground terminal	<ul style="list-style-type: none"> ▪ Screw: A4 ▪ Spring washer: A4 ▪ Clamp: 316L (1.4404) ▪ Holder: 316L (1.4404)
9	Nameplate	<ul style="list-style-type: none"> ▪ Plate: 316L (1.4404) ▪ Groove pin: A4 (1.4571)

1) For the version with M12 plug the sealing material is Viton.

2) For the version with 7/8" plug, the sealing material is NBR.

Materials: GT19 housing (plastic)

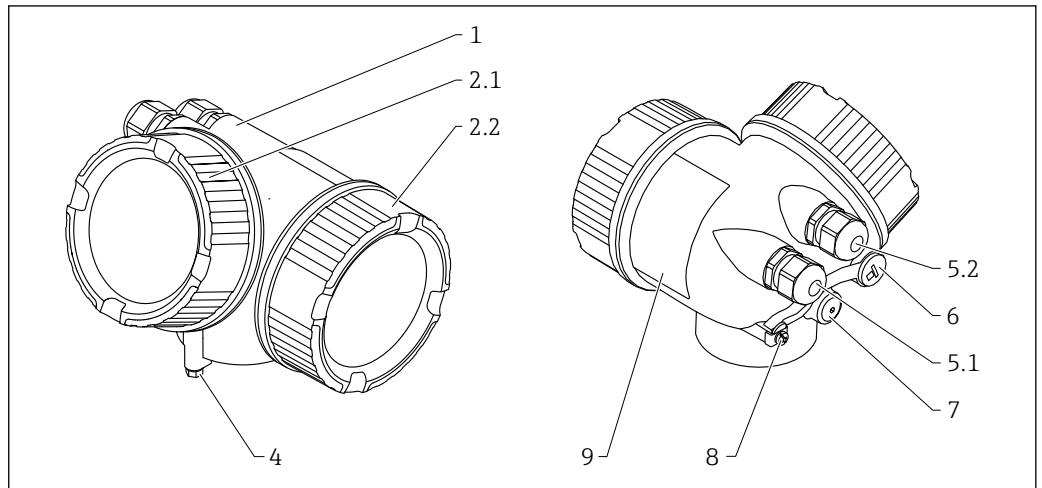

A0013788

No.	Part	Material
1	Housing	PBT
2.1	Cover of the electronics compartment	<ul style="list-style-type: none"> ▪ Cover glass: PC ▪ Cover frame: PBT-PC ▪ Cover seal: EPDM ▪ Thread-coating: Graphite-based lubricant varnish
2.2	Cover of the terminal compartment	<ul style="list-style-type: none"> ▪ Cover: PBT ▪ Cover seal: EPDM ▪ Thread-coating: Graphite-based lubricant varnish
4	Lock at the housing neck	<ul style="list-style-type: none"> ▪ Screw: A4-70 ▪ Clamp: 316L (1.4404)
5.1	Dummy plug, cable gland, adapter or plug (depending on the device version)	<ul style="list-style-type: none"> ▪ Dummy plug, depending on the device version: <ul style="list-style-type: none"> - PE - PBT-GF ▪ Cable gland, depending on the device version: <ul style="list-style-type: none"> - Nickel-plated brass (CuZn) - PA ▪ Adapter: 316L (1.4404/1.4435) ▪ Seal: EPDM ▪ M12 plug: Nickel-plated brass ¹⁾ ▪ 7/8" plug: 316 (1.4401) ²⁾
5.2	Dummy plug, cable gland or adapter (depending on the device version)	<ul style="list-style-type: none"> ▪ Dummy plug, depending on the device version: <ul style="list-style-type: none"> - PE - PBT-GF - Nickel-plated steel ▪ Cable gland, depending on the device version: <ul style="list-style-type: none"> - Nickel-plated brass (CuZn) - PA ▪ Adapter: 316L (1.4404/1.4435) ▪ Seal: EPDM
6	Dummy plug or M12 socket (depending on the device version)	<ul style="list-style-type: none"> ▪ Dummy plug: Nickel-plated brass (CuZn) ▪ M12 socket: Nickel-plated GD-Zn
7	Pressure relief stopper	Nickel-plated brass (CuZn)
8	Ground terminal	<ul style="list-style-type: none"> ▪ Screw: A2 ▪ Spring washer: A4 ▪ Clamp: 304 (1.4301) ▪ Holder: 304 (1.4301)
9	Adhesive nameplate	Plastic

1) For the version with M12 plug the sealing material is Viton.
 2) For the version with 7/8" plug, the sealing material is NBR.

Materials: GT20 housing
(die-cast aluminum, powder-coated)

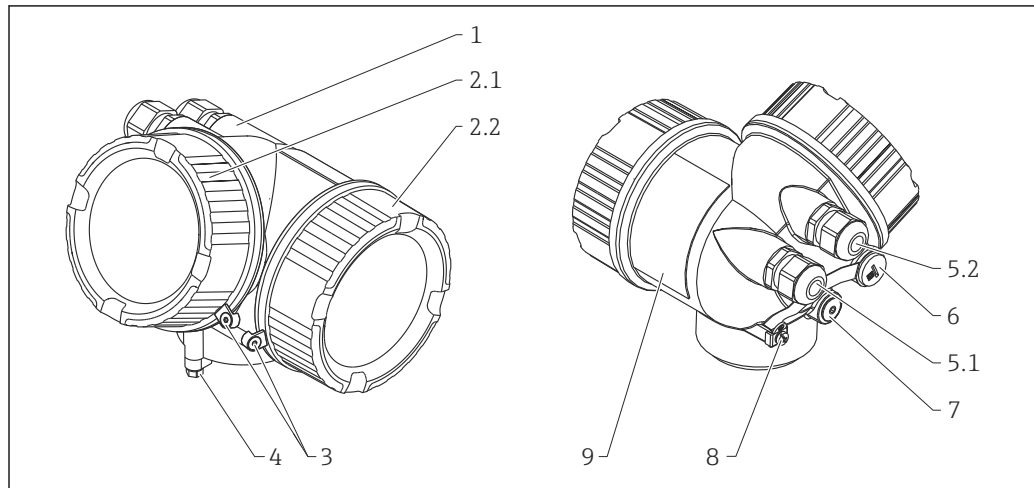

A0013788

Nr.	Part	Material
1	Housing, RAL 5012 (blue)	<ul style="list-style-type: none"> ■ Housing: AlSi10Mg(<0,1% Cu) ■ Coating: Polyester
2.1	Cover of the electronics compartment; RAL 7035 (gray)	<ul style="list-style-type: none"> ■ Cover: AlSi10Mg(<0,1% Cu) ■ Window: Glass ■ Cover seal: NBR ■ Seal of the window: NBR ■ Thread-coating: Graphite-based lubricant varnish
2.2	Cover of the terminal compartment; RAL 7035 (gray)	<ul style="list-style-type: none"> ■ Cover: AlSi10Mg(<0,1% Cu) ■ Cover seal: NBR ■ Thread-coating: Graphite-based lubricant varnish
3	Cover lock	<ul style="list-style-type: none"> ■ Screw: A4 ■ Clamp: 316L (1.4404)
4	Lock at the housing neck	<ul style="list-style-type: none"> ■ Screw: A4-70 ■ Clamp: 316L (1.4404)
5.1	Dummy plug, cable gland, adapter or plug (depending on the device version)	<ul style="list-style-type: none"> ■ Dummy plug, depending on the device version: <ul style="list-style-type: none"> - PE - PBT-GF ■ Cable gland, depending on the device version: <ul style="list-style-type: none"> - Nickel-plated brass (CuZn) - PA ■ Adapter: 316L (1.4404/1.4435) ■ Seal: EPDM ■ M12 plug: Nickel-plated brass ¹⁾ ■ 7/8" plug: 316 (1.4401) ²⁾
5.2	Dummy plug, cable gland or adapter (depending on the device version)	<ul style="list-style-type: none"> ■ Dummy plug, depending on the device version: <ul style="list-style-type: none"> - PE - PBT-GF - Nickel-plated steel ■ Cable gland, depending on the device version: <ul style="list-style-type: none"> - Nickel-plated brass (CuZn) - PA ■ Adapter: 316L (1.4404/1.4435) ■ Seal: EPDM
6	Dummy plug or M12 socket (depending on the device version)	<ul style="list-style-type: none"> ■ Dummy plug : Nickel-plated brass (CuZn) ■ M12 socket: Nickel-plated GD-Zn
7	Pressure relief stopper	Nickel-plated brass (CuZn)

Nr.	Part	Material
8	Ground terminal	<ul style="list-style-type: none"> ▪ Screw: A2 ▪ Spring washer: A2 ▪ Clamp: 304 (1.4301) ▪ Holder: 304 (1.4301)
9	Adhesive nameplate	Plastic

- 1) For the version with M12 plug the sealing material is Viton.
- 2) For the version with 7/8" plug, the sealing material is NBR.

Materials: Antenna and process connection

FMR56

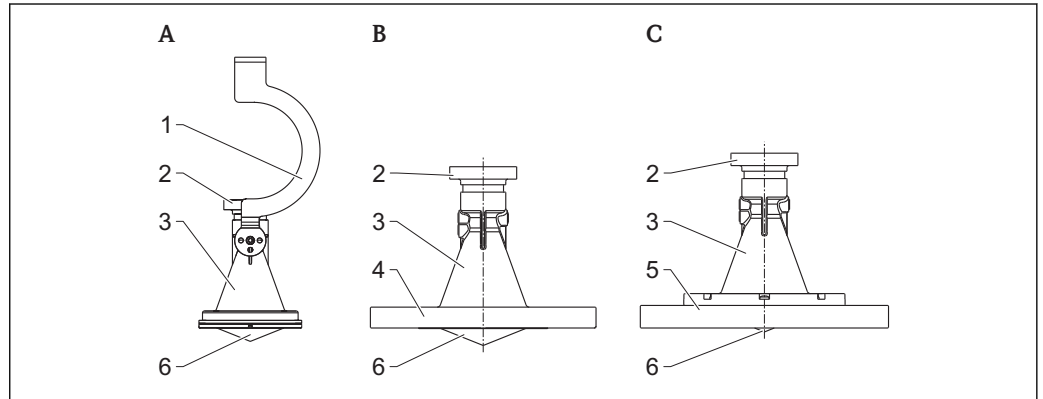

A0018950

- A Standard version with mounting bracket
 B Horn antenna with slip-on flange
 C Horn antenna with flange and adapter ring

Pos.	Part	Material
1	Mounting bracket	304 (1.4301)
	Screw	A2
	Nordlock washer	A4
2	Housing adapter	304 (1.4301)
3	Horn	PBT
4	Slip-on flange	PP
5	Flange and adapter ring	PP
	Screw	A2
	Seal	FKM
6	Focusing lens	PP
	Seal	VMQ

FMR57

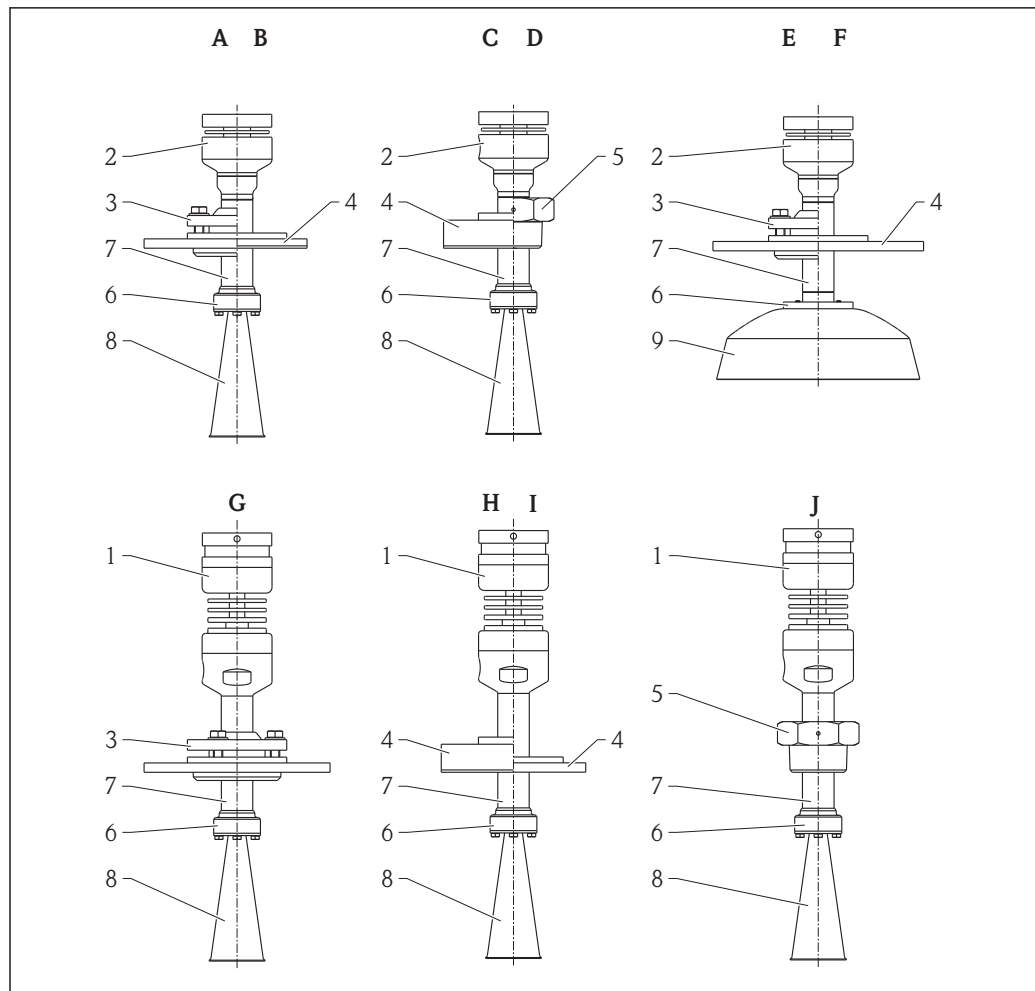

A0018958

- A *Horn standard version with alignment device and UNI flange*
- B *Horn standard version with UNI flange*
- C *Horn standard version with standard flange*
- D *Horn standard version with screw-in adapter*
- E *Paraboloid version with alignment device and UNI flange*
- F *Paraboloid version with UNI flange*
- G *Horn high temperature version with alignment device and UNI flange*
- H *Horn high temperature version with standard flange*
- I *Horn high temperature version with UNI flange*
- J *Horn high temperature version with threaded connection*

Pos.	Part	Material	
1	Housing adapter	316L (1.4404)	
	Temperature reduction	316L (1.4404)	
	Intermediate adapter	316L (1.4404)	
	Purge-air connection	316L (1.4404)	
	Plug	A4	316L (1.4404)
	Adapter (G→NPT)	316L (1.4404)	
2	Housing adapter	316L (1.4404)	
	Plug	A4	316L (1.4404)
	Adapter (G→NPT)	316L (1.4404)	
	Seal	FKM	PTFE (tape)

Pos.	Part	Material	
3	Flange	316L (1.4404)	
	Ball	316L (1.4404)	
	Screws	A2	
	Spring-lock washer	1.4310	
	Clamping flange	316L (1.4404)	
	Adapter	316L (1.4404)	
	Seal (except for version "G")	FKM	
4	Flange	316L (1.4404/1.4435)	
	Adapter	316L (1.4404)	
5	Process connection	316L (1.4404)	
6	Process separating parts	316L (1.4404)	
	Adapter Horn/Parabolic	316L (1.4404)	
7	Tube	316L (1.4404)	
8	Horn	316L (1.4404)	
	Screws	A4	
	Process separating cone	Standard: PEEK	High temperature: PI
	Seal	Standard: FKM	High temperature: Graphite
9	Parabolic reflector	316L (1.4404)	
	Screws	A4	
	Feed	PTFE	
	Seal	FKM	

Materials: Weather protection cover

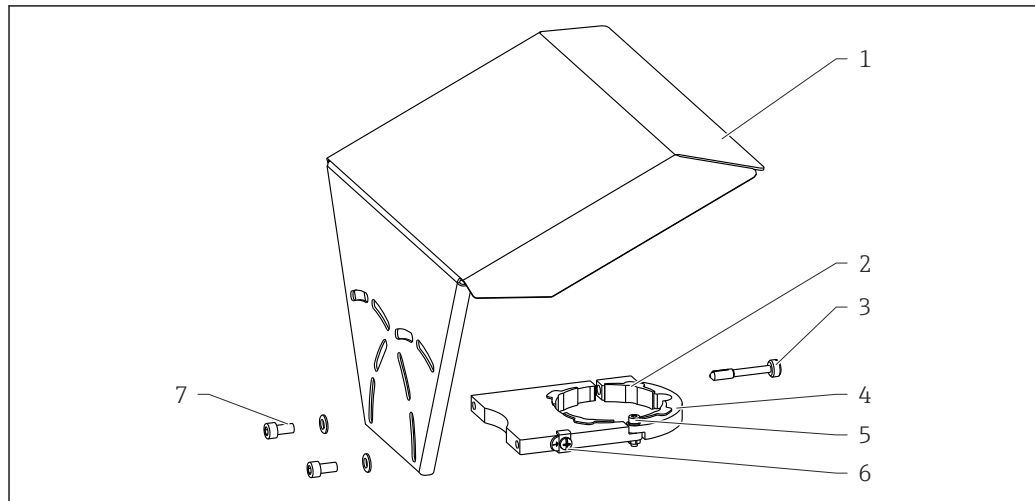

A0015473

No	Part: Material
1	Protection cover: 316L (1.4404)
2	Molded rubber part (4x): EPDM
3	Clamping screw: 316L (1.4404) + carbon fibre
4	Bracket: 316L (1.4404)
5	<ul style="list-style-type: none"> ▪ Cheese head screw: A4-70 ▪ Nut: A4 ▪ Spring washer: A4
6	Ground terminal <ul style="list-style-type: none"> ▪ Screw: A4 ▪ Spring washer: A4 ▪ Clamp: 316L (1.4404) ▪ Holder: 316L (1.4404)
7	<ul style="list-style-type: none"> ▪ Washer: A4 ▪ Cheese head screw: A4-70

Operability

Operating concept

Operator-oriented menu structure for user-specific tasks

- Commissioning
- Operation
- Diagnostics
- Expert level

Operating languages

- English
- Deutsch
- Français
- Español
- Italiano
- Nederlands
- Portuguesa
- Polski
- русский язык (Russian)
- Svenska
- Türkçe
- 中文 (Chinese)
- 日本語 (Japanese)
- 한국어 (Korean)
- Bahasa Indonesia
- tiếng Việt (Vietnamese)
- čeština (Czech)



Feature 500 of the product structure determines which of these languages is preset on delivery.

Quick and save commissioning

- Interactive wizard with graphical interface for easy commissioning via FieldCare/DeviceCare
- Menu guidance with brief explanations of the individual parameter functions
- Standardized operation at the device and in the operating tools

Integrated data storage device (HistoROM)

- Enables transfer of configuration when changing electronic modules
- Records up to 100 event messages in the device
- Records up to 1000 measured values in the device
- Saves the signal curve on commissioning which can later be used as a reference.

Efficient diagnostics increase measurement reliability

- Remedy information is integrated in plain text
- Diverse simulation options and line recorder functions

Local operation

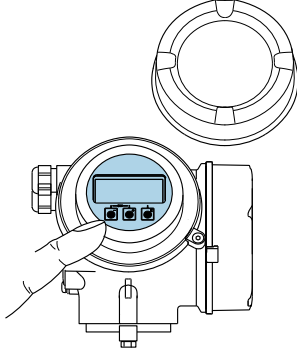
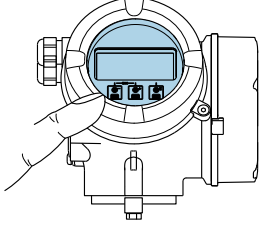
Operation with	Pushbuttons	Touch Control
Order code for "Display; Operation"	Option C "SD02"	Option E "SD03"
		
Display elements	4-line display	4-line display white background lighting; switches to red in event of device error
	Format for displaying measured variables and status variables can be individually configured	
	Permitted ambient temperature for the display: -20 to +70 °C (-4 to +158 °F) The readability of the display may be impaired at temperatures outside the temperature range.	
Operating elements	local operation with 3 push buttons (☐, ☐, ☐)	external operation via touch control; 3 optical keys: ☐, ☐, ☐
	Operating elements also accessible in various hazardous areas	
Additional functionality	Data backup function The device configuration can be saved in the display module.	
	Data comparison function The device configuration saved in the display module can be compared to the current device configuration.	
	Data transfer function The transmitter configuration can be transmitted to another device using the display module.	

Operation with remote display and operating module FHX50

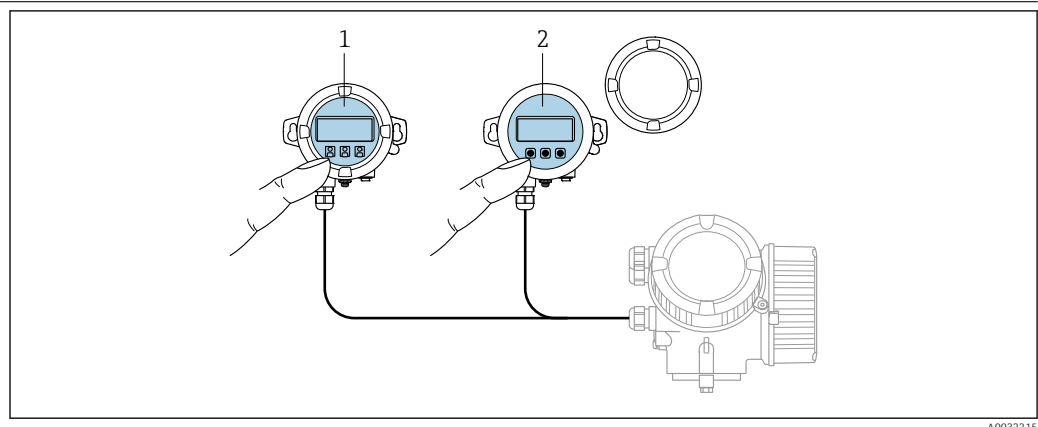

31 FHX50 operating options

- 1 Housing of the remote display and operating module FHX50
- 2 Display and operating module SD02, push buttons; cover must be removed
- 3 Display and operating module SD03, optical keys; can be operated through the glass of the cover

Remote operation

Via HART protocol

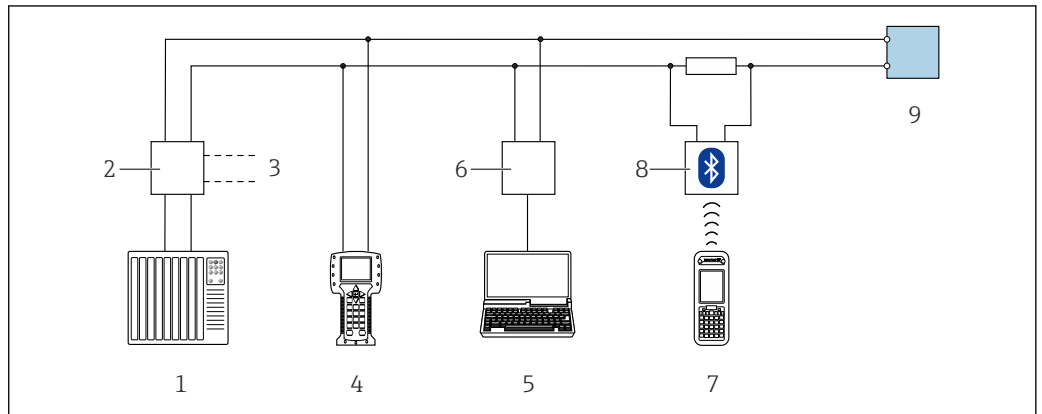

A0028746

32 Options for remote operation via HART protocol

- 1 PLC (programmable logic controller)
- 2 Transmitter power supply unit, e.g. RN22 1N (with communication resistor)
- 3 Connection for Commubox FXA191, FXA195 and Field Communicator 375, 475
- 4 Field Communicator 475
- 5 Computer with operating tool (e.g. DeviceCare/FieldCare , AMS Device Manager, SIMATIC PDM)
- 6 Commubox FXA191 (RS232) or FXA195 (USB)
- 7 Field Xpert SFX350/SFX370
- 8 VIATOR Bluetooth modem with connecting cable
- 9 Transmitter

Via PROFIBUS PA protocol

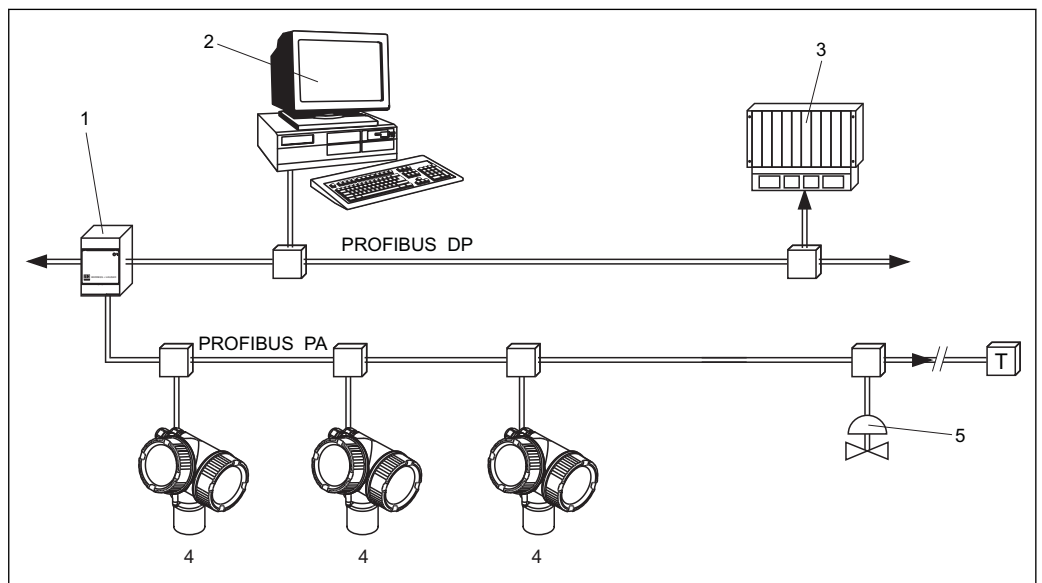

A0015775

- 1 Segment coupler
- 2 Computer with Profiboard/Proficard and operating tool (e.g. DeviceCare/FieldCare)
- 3 PLC (Programmable Logic Controller)
- 4 Transmitter
- 5 Additional functions (valves etc.)

Via FOUNDATION Fieldbus

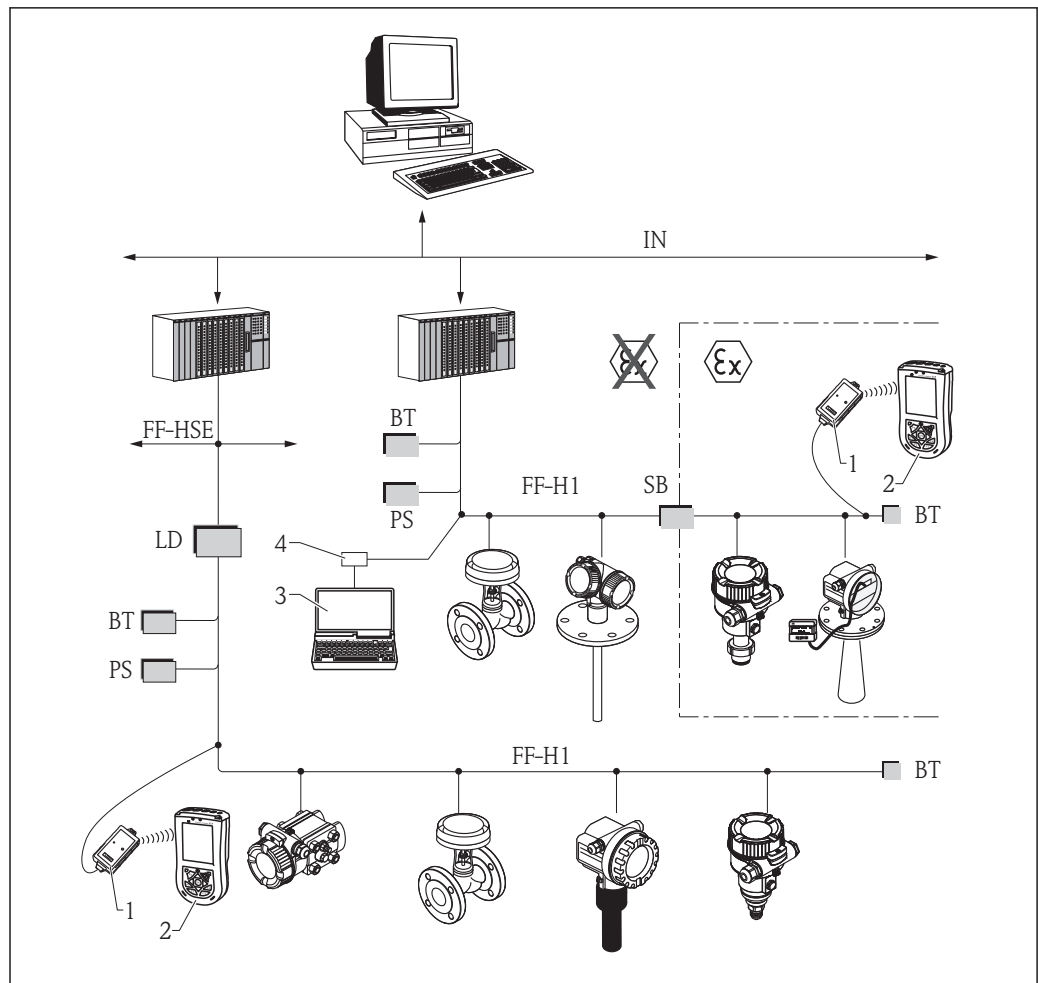

A0017188

33 FOUNDATION Fieldbus system architecture with associated components

- 1 FFblue Bluetooth modem
- 2 Field Xpert SFX350/SFX370
- 3 DeviceCare/FieldCare
- 4 NI-FF interface card

IN	Industrial network
FF-HSE	High Speed Ethernet
FF-H1	FOUNDATION Fieldbus-H1
LD	Linking Device FF-HSE/FF-H1
PS	Bus Power Supply
SB	Safety Barrier
BT	Bus Terminator

Via service interface (CDI)

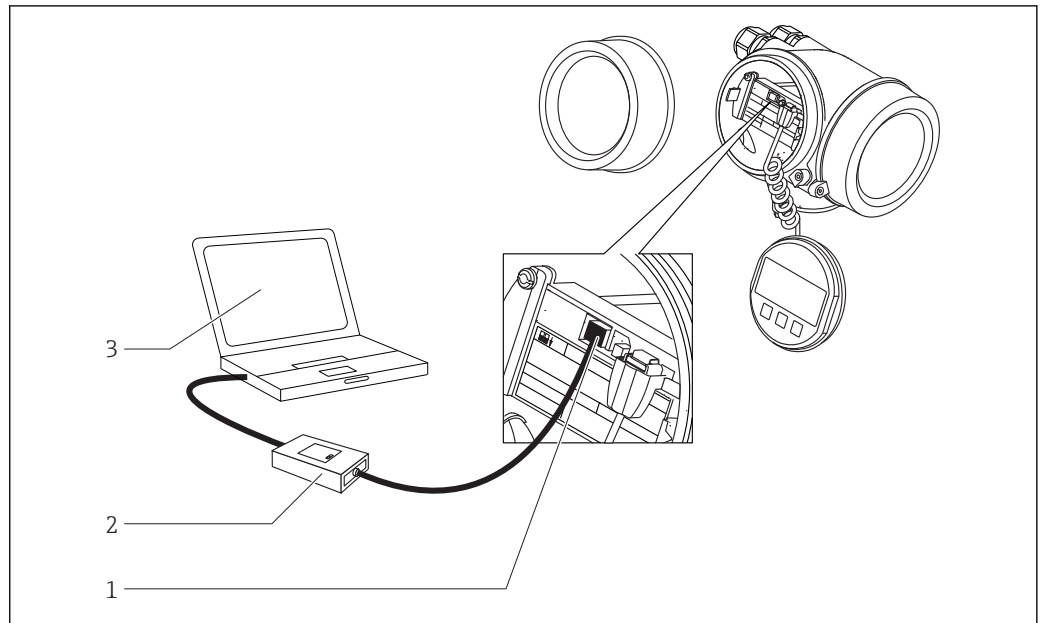

A0032466

- 1 Service interface (CDI) of the measuring device (= Endress+Hauser Common Data Interface)
- 2 Commubox FXA291
- 3 Computer with DeviceCare/FieldCare operating tool

SupplyCare inventory management software

SupplyCare is a web-based operating program for coordinating the flow of material and information along the supply chain. SupplyCare provides a comprehensive overview of the levels of geographically distributed tanks and silos, for instance, providing complete transparency over the current inventory situation, regardless of time and location.

Based on the measuring and transmission technology installed onsite, the current inventory data are collected and sent to SupplyCare. Critical levels are clearly indicated and calculated forecasts provide additional security for material requirements planning.

The main functions of SupplyCare:

Inventory visualization

SupplyCare determines the inventory levels in tanks and silos at regular intervals. It displays current and historical inventory data and calculated forecasts of future demand. The overview page can be configured to suit the user's preferences.

Master data management

With SupplyCare you can create and manage the master data for locations, companies, tanks, products and users, as well as user authorization.

Report Configurator

The Report Configurator can be used to create personalized reports quickly and easily. The reports can be saved in a variety of formats, such as Excel, PDF, CSV and XML. The reports can be transmitted in many ways, such as by http, ftp or e-mail.

Event management

Events, such as when levels drop below the safety stock level or plan points, are indicated by the software. In addition, SupplyCare can also notify pre-defined users by e-mail.

Alarms

If technical problems occur, e.g. connection issues, alarms are triggered and alarm e-mails are sent to the System Administrator and the Local System Administrator.

Delivery planning

The integrated delivery planning function automatically generates an order proposal if a pre-set minimum inventory level is undershot. Scheduled deliveries and disposals are monitored continuously by SupplyCare. SupplyCare notifies the user if scheduled deliveries and disposals are not going to be met as planned.

Analysis

In the Analysis module, the most important indicators for the inflow and outflow of the individual tanks are calculated and displayed as data and charts. Key indicators of material management are automatically calculated and form the basis for optimizing the delivery and storage process.

Geographical visualization

All the tanks and the tank inventories are represented graphically on a map (based on Google Maps). The tanks and inventory situations can be filtered by tank group, product, supplier or location.

Multi-language support

The multi-language user interface supports 9 languages, thereby enabling global collaboration on a single platform. The language and settings are recognized automatically using the browser settings.

SupplyCare Enterprise

SupplyCare Enterprise runs by default as a service under Microsoft Windows on an application server in an Apache Tomcat environment. The operators and administrators operate the application via a Web browser from their workstations.

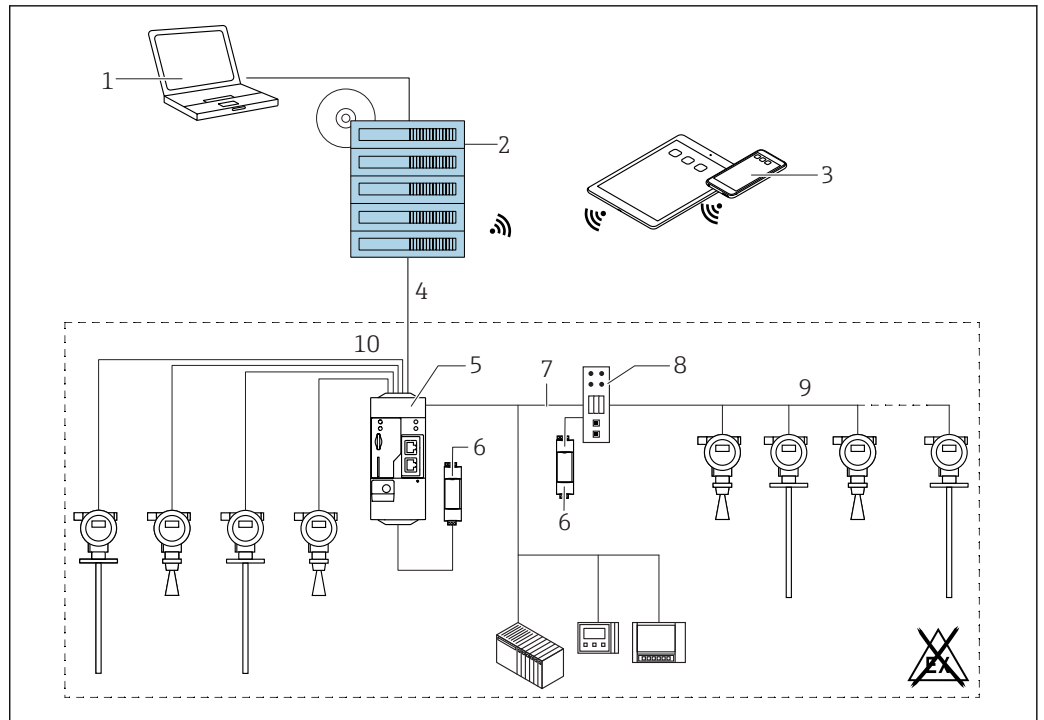

A0034288

34 Example of inventory management platform with SupplyCare Enterprise SCE30B

- 1 SupplyCare Enterprise (via Web browser)
- 2 SupplyCare Enterprise installation
- 3 SupplyCare Enterprise on mobile devices (via Web browser)
- 4 Ethernet/WLAN/UMTS
- 5 Fieldgate FXA42
- 6 Power supply 24 V DC
- 7 Modbus TCP via Ethernet as server/client
- 8 Converter from Modbus to HART Multidrop
- 9 HART Multidrop
- 10 4 x 4 to 20 mA analog input (2-wire/4-wire)

Cloud-based application: SupplyCare Hosting

SupplyCare Hosting is offered as a hosting service (software as a service). Here, the software is installed within the Endress+Hauser IT infrastructure and made available to the user in the Endress+Hauser portal.

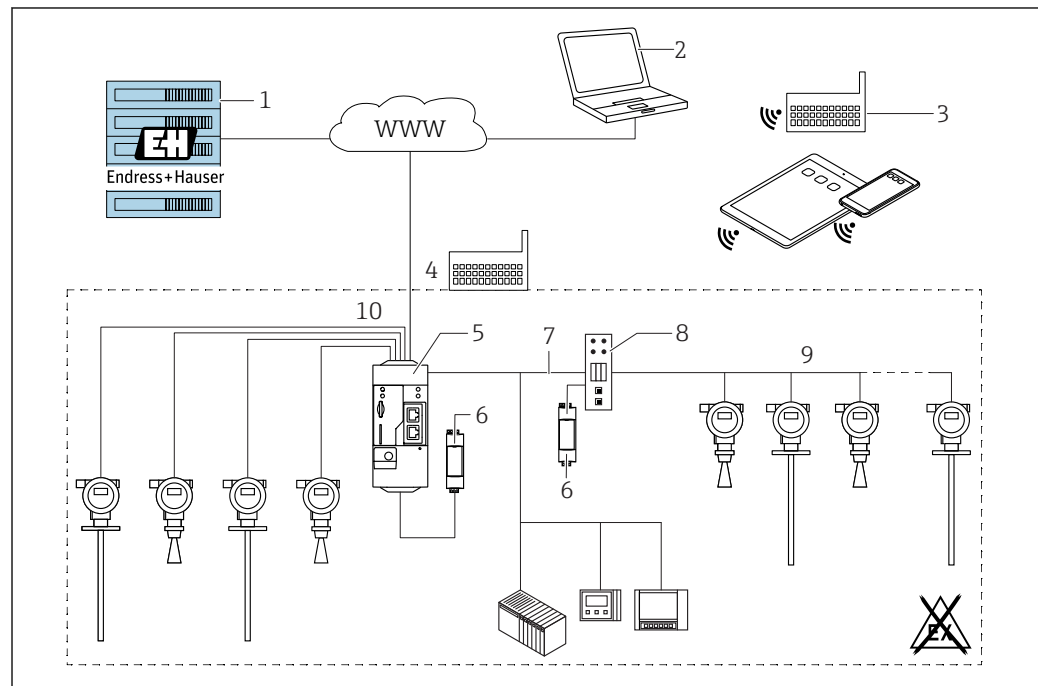

A0034289

35 Example of inventory management platform with SupplyCare Hosting SCH30

- 1 SupplyCare Hosting installation in Endress+Hauser data center
- 2 PC workstation with Internet connection
- 3 Warehouse locations with Internet connection via 2G/3G with FXA42 or FXA30
- 4 Warehouse locations with Internet connection with FXA42
- 5 Fieldgate FXA42
- 6 Power supply 24 V DC
- 7 Modbus TCP via Ethernet as server/client
- 8 Converter from Modbus to HART Multidrop
- 9 HART Multidrop
- 10 4 x 4 to 20 mA analog input (2-wire/4-wire)

With SupplyCare Hosting, users do not need to make the initial software purchase or install and run the IT infrastructure needed. Endress+Hauser constantly update SupplyCare Hosting and enhance the capability of the software in conjunction with the customer. The hosted version of SupplyCare is thus always up-to-date and can be customized to meet different customer requirements. Other services are also offered in addition to the IT infrastructure and the software that is installed in a secure, redundant Endress+Hauser data center. These services include defined availability of the global Endress+Hauser Service and Support Organization and defined response times in a service event.

Certificates and approvals



Currently available certificates and approvals can be called up via the product configurator.

CE mark The measuring system meets the legal requirements of the applicable EC guidelines. These are listed in the corresponding EC Declaration of Conformity together with the standards applied.
Endress+Hauser confirms successful testing of the device by affixing to it the CE mark.

RoHS The measuring system complies with the substance restrictions of the Restriction on Hazardous Substances Directive 2011/65/EU (RoHS 2).

RCM-Tick marking The supplied product or measuring system meets the ACMA (Australian Communications and Media Authority) requirements for network integrity, interoperability, performance characteristics as well as health and safety regulations. Here, especially the regulatory arrangements for electromagnetic compatibility are met. The products are labelled with the RCM- Tick marking on the name plate.



A0029561

Ex approval

- ATEX
- IEC Ex
- CSA
- FM
- NEPSI
- KC
- INMETRO
- TIIS (in preparation)

Additional safety instructions must be observed for applications in hazardous areas. They are contained in the separate "Safety Instructions" (XA) document, which is included in the scope of delivery. Reference is made to the XA on the nameplate of the device.



Details on the available certificates as well as the associated XAs can be found in the **Associated documentation** chapter in the **Safety instructions** section: → 98.

Dual seal according to ANSI/ISA 12.27.01 The devices have been designed according to ANSI/ISA 12.27.01 as dual seal devices, allowing the user to waive the use and save the cost of installing external secondary process seals in the conduit as required by the process sealing sections of ANSI/NFPA 70 (NEC) and CSA 22.1 (CEC) These instruments comply with the North-American installation practice and provide a very safe and cost-saving installation for pressurized applications with hazardous fluids.

Further information can be found in the Safety Instructions (XA) of the relevant devices.

Functional Safety Used for level monitoring (MIN, MAX, range) up to SIL 3 (homogeneous or inhomogeneous redundancy), independently assessed by TÜV Rheinland as per IEC 61508. Other information see documentation SD01087F: "Functional Safety Manual".

WHG WHG approval: Z-65.16-524

Pressure equipment with allowable pressure ≤ 200 bar (2 900 psi) Pressure instruments with a flange and threaded boss that do not have a pressurized housing do not fall within the scope of the Pressure Equipment Directive, irrespective of the maximum allowable pressure.

Reasons:

According to Article 2, point 5 of EU Directive 2014/68/EU, pressure accessories are defined as "devices with an operational function and having pressure-bearing housings".

If a pressure instrument does not have a pressure-bearing housing (no identifiable pressure chamber of its own), there is no pressure accessory present within the meaning of the Directive.

Marine certificate

Device	Marine certificate ¹⁾				
	GL	ABS	LR	BV	DNV
FMR56	-	-	-	-	-
FMR57	✓	✓	✓	✓	✓

1) see ordering feature 590 "Additional approval"

Radio standard
EN302729-1/2

The devices Micropilot FMR50, FMR51, FMR52, FMR56 and FMR57 are conform with the LPR (Level Probing Radar) standard EN302729-1/2. The devices are allowed to be used inside or outside of closed bins or tanks in countries of the EU and the EFTA. Precondition is that the country itself already has implemented the directive.

At present, the following countries have already implemented the directive:

Belgium, Bulgaria, Germany, Denmark, Estonia, France, Greece, Great Britain, Ireland, Iceland, Italy, Liechtenstein, Lithuania, Latvia, Malta, Netherland, Norway, Austria, Poland, Romania, Sweden, Switzerland, Slovakia, Spain, Czech Republic and Cyprus.

All countries not mentioned above are at present in the implementation phase.

For the use of the devices outside of closed bins or tanks, the following has to be observed:

1. The installation has to be done by trained personnel.
2. The antenna of the device has to be mounted on a fixed place and vertically to the bottom.
3. The mounting place has to be in a distance of at least 4 km to the mentioned astronomical stations or an appropriate permission has to be issued by the national authority. If the device is mounted at a distance of 4 to 40 km from the stations mentioned, the maximum mounting height is restricted to 15 m (49 ft).

Astronomical stations

Country	Name of the station	Geographical latitude	Geographical longitude
Germany	Effelsberg	50°31'32" N	06°53'00" E
Finland	Metsähovi	60°13'04" N	24°23'37" E
	Tuorla	60°24'56" N	24°26'31" E
France	Plateau de Bure	44°38'01" N	05°54'26" E
	Floirac	44°50'10" N	00°31'37" W
United Kingdom	Cambridge	52°09'59" N	00°02'20" E
	Damhall	53°09'22" N	02°32'03" W
	Jodrell Bank	53°14'10" N	02°18'26" W
	Knockin	52°47'24" N	02°59'45" W
	Pickmere	53°17'18" N	02°26'38" W
Italy	Medicina	44°31'14" N	11°38'49" E
	Noto	36°52'34" N	14°59'21" E
	Sardinia	39°29'50" N	09°14'40" E
Poland	Krakow Fort Skala	50°03'18" N	19°49'36" E
Russia	Dmitrov	56°26'00" N	37°27'00" E
	Kalyazin	57°13'22" N	37°54'01" E
	Pushchino	54°49'00" N	37°40'00" E
	Zelenchukskaya	43°49'53" N	41°35'32" E
Sweden	Onsala	57°23'45" N	11°55'35" E
Switzerland	Bleien	47°20'26" N	08°06'44" E
Spain	Yebes	40°31'27" N	03°05'22" W

Country	Name of the station	Geographical latitude	Geographical longitude
	Robledo	40°25'38" N	04°14'57" W
Hungary	Penc	47°47'22" N	19°16'53" E

 In general the requirements of EN 302729-1/2 have to be taken in consideration.

Radio standard EN302372-1/2 The devices Micropilot FMR50, FMR51, FMR52, FMR53, FMR54, FMR56 and FMR57 are conform with the TLPR (Tanks Level Probing Radar) standard EN302372-1/2 and can always be used in closed tanks or bins. For installation, points a to f in Annex B of EN302372-1 have to be taken into account.

FCC / Industry Canada This device complies with Part 15 of the FCC rules. Operation is subject to the following two conditions: (1) This device may not cause harmful interference, and (2) this device must accept any interference received, including interference that may cause undesired operation.

Canada CNR-Gen Section 7.1.3

This device complies with Industry Canada licence-exempt RSS standard(s). Operation is subject to the following two conditions: (1) This device may not interference, and (2) this device must accept any interference, including interference that may cause undesired operation of the device.

Le présent appareil est conforme aux CNR d'Industrie Canada applicables aux appareils radio exempts de licence. L'exploitation est autorisée aux deux conditions suivantes : (1) l'appareil ne doit pas produire de brouillage, et (2) l'utilisateur de l'appareil doit accepter tout brouillage radioélectrique subi, même si le brouillage est susceptible d'en compromettre le fonctionnement.

[Any] changes or modifications not expressly approved by the party responsible for compliance could void the user's authority to operate the equipment.

In addition, the devices FMR50⁵⁾, FMR51⁶⁾, FMR52⁷⁾, FMR56 and FMR57 are compliant with the LPR (Level probe radar) regulation also for free space applications according to the FCC Code of Federal Regulations, CFR 47, Part 15, Sections 15.205, 15.207, 15.209, 15.256 for antenna sizes bigger than 50 mm (2.0 in)⁸⁾. For these applications the devices must be professionally installed in a downward operating position. In addition, the devices are not allowed to be mounted in a zone of 4 km around RAS stations and within a radius of 40 km around RAS stations the maximum operation height of devices is 15 m (49 ft) above ground.

Japanese radio approval The devices FMR50, FMR51, FMR52, FMR54 and FMR57 comply with the Japanese Radio Law, Article 6, Section 1(1).

CRN approval Some device versions have a CRN approval. Devices are CRN approved if the following two conditions are met:



- The device has a CSA approval (Product structure: Feature 010 "Approval")
- The device has a CRN approved process connection according to the following table.

Feature 100 of the product structure	Process connection
AGJ	NPS 3" Cl.150 RF, 316/316L
AHJ	NPS 4" Cl.150 RF, 316/316L
RGJ	Thread ANSI MNPT1-1/2, 316L
RVJ	Thread EN10226 R1-1/2, 316L
XWG	UNI slip on flange 3"/DN80/80, PP

5) Except of FMR50-#####BM* (Horn 40mm/1-1/2", PVDF encapsulated)
 6) Except for FMR51-#####BA* (Horn 40mm/1-1/2") and FMR51-#####BB* (Horn 50mm/2")
 7) Except for FMR52-#####BO* (Horn 50mm/2", flush mount)
 8)

Feature 100 of the product structure	Process connection
XZG	UNI slip on flange 4"/DN100/100, PP
XOG	UNI slip on flange 6"/DN150/150, PP

-  Process connections without CRN approval are not included in this table.
- Refer to the product structure to see which process connections are available for a specific device type.
 - For some process connections not listed in the product structure a CRN approval is available on request.
 - CRN approved devices are marked with the registration number OF15872.5C on the nameplate.

-  For device versions listed in the table below, the maximum allowed pressure is reduced if they have a CRN approval. For device versions not listed in the table below the pressure range as indicated in the "Process" chapter →  49 is not affected by the CRN approval.

Product	Antenna ¹⁾	Process connection ²⁾	Seal ³⁾	max. pressure
FMR50/FMR56	BN: Horn 80mm/3"	XWG: UNI slip-on flange 3"		1.6 bar (23.2 psi)
		XZG: UNI slip-on flange 4"		1.5 bar (21.75 psi)
		XOG: UNI slip-on flange 6"		1.5 bar (21.75 psi)
	BR: Horn 100mm/4"	XZG: UNI slip-on flange 4"		12 bar (17.4 psi)
		XOG: UNI slip-on flange 6"		1.8 bar (26.1 psi)

- 1) Feature 070 of the product structure
- 2) Feature 100 of the product structure
- 3) Feature 090 of the product structure

Track record

FMR5x is the upgrade model of the corresponding FMR2xx series.

Test, Certificate

Feature 580 "Test, Certificate"	Designation	Available for
JD	3.1 Material certificate, pressurized parts, EN10204-3.1 inspection certificate	FMR57
KV	Conformity to ASME B31.3: The dimensions, materials of construction, pressure / temperature ratings and identification markings of the device comply with the requirements of ASME B31.3	FMR57



Test reports, declarations and material test certificates can be obtained electronically from the *W@M Device Viewer* :

Enter the serial number from the nameplate (www.endress.com/deviceviewer)

This applies to the options of the following ordering features:

- 550 "Calibration"
- 580 "Test, Certificate"

Product documentation on paper

Test reports, declarations and material certificates can be ordered as hardcopies via ordering feature 570 "Service", option I7 „Product documentation on paper“. The printouts will be enclosed in the product delivery.

Other standards and guidelines

- EN 60529
Degrees of protection by housing (IP code)
- EN 61010-1
Protection Measures for Electrical Equipment for Measurement, Control, Regulation and Laboratory Procedures.
- IEC/EN 61326
"Emission in accordance with Class A requirements". Electromagnetic compatibility (EMC requirements)
- NAMUR NE 21
Electromagnetic compatibility (EMC) of industrial process and laboratory control equipment.
- NAMUR NE 43
Standardization of the signal level for the breakdown information of digital transmitters with analog output signal.
- NAMUR NE 53
Software of field devices and signal-processing devices with digital electronics
- NAMUR NE 107
Status classification as per NE107
- NAMUR NE 131
Requirements for field devices for standard applications
- IEC61508
Functional safety of electrical/electronic/programmable electronic safety-related systems

Ordering information

Ordering information

Detailed ordering information is available from the following sources:

- In the Product Configurator on the Endress+Hauser website: www.endress.com -> Click "Corporate" -> Select your country -> Click "Products" -> Select the product using the filters and search field -> Open product page -> The "Configure" button to the right of the product image opens the Product Configurator.
- From your Endress+Hauser Sales Center: www.addresses.endress.com



Product Configurator - the tool for individual product configuration

- Up-to-the-minute configuration data
- Depending on the device: Direct input of measuring point-specific information such as measuring range or operating language
- Automatic verification of exclusion criteria
- Automatic creation of the order code and its breakdown in PDF or Excel output format
- Ability to order directly in the Endress+Hauser Online Shop

3-point linearity protocol

 The following notes must be taken into account if option F3 ("3 point linearity protocol") has been selected in feature 550 ("Calibration").

The 3 points of the linearity protocol are defined as follows:

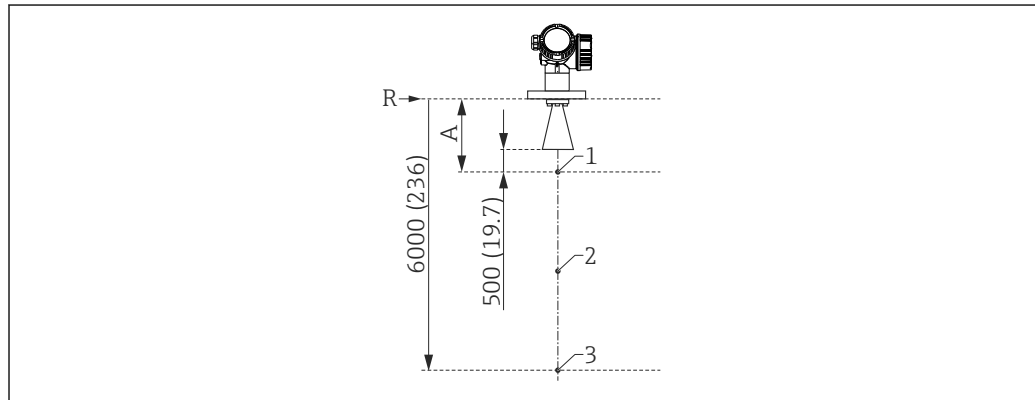

A0023272

 36 Points of the 3-point linearity protocol; Dimensions: mm (in)

- A Distance from reference point R to first measuring point
- R Reference point of the measurement
- 1 First measuring point
- 2 Second measuring point (centrally between first and third measuring point)
- 3 Third measuring point

Measuring point	Position
1 st measuring point	<ul style="list-style-type: none"> ■ At the distance A from the reference point ■ A = antenne length + antenna extension (if present) + 500 mm (19.7 in) ■ Minimum distance: $A_{\min} = 1\,000$ mm (39.4 in)
2 nd measuring point	centrally between 1 st and 3 rd measuring point
3 rd measuring point	6 000 mm (236 in) below the reference point, R

 The position of the measuring points may vary by ± 1 cm (± 0.04 in).

 The linearity is checked under reference conditions.

5-point linearity protocol

i The following notes must be taken into account if option F4 ("5 point linearity protocol") has been selected in feature 550 ("Calibration").

The five points of the linearity protocol are evenly distributed across the measuring range (0% to 100%). In order to define the measuring range, **Empty calibration** (E) and **Full calibration** (F) have to be specified ⁹⁾.

The following restrictions have to be taken into account when defining E and F:

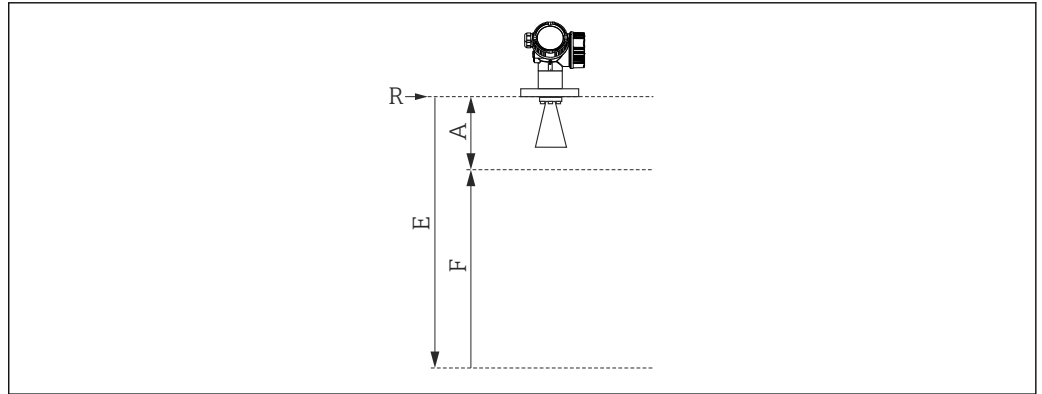

A0017983

Device version	Minimum distance between reference point (R) and 100% level	Minimum span	Maximum value for "Empty calibration"
FMR56/FMR57 Without antenna extension	$A \geq \text{antenna length} + 600 \text{ mm (24 in)}^1$		
FMR57 with antenna extension ²⁾	$A \geq \text{antenna length} + \text{antenna extension} + 600 \text{ mm (24 in)}^3$	$F \geq 400 \text{ mm (16 in)}$	$E \leq 20 \text{ m (66 ft)}$

- 1) Minimum value for FMR57: 861 mm (16 in)
- 2) Feature 610 "Accessory Mounted", option OP or OT
- 3) Minimum value: 861 mm (16 in)

i The linearity is checked under reference conditions.

i The selected values of **Empty calibration** and **Full calibration** are only used to record the linearity protocol and are reset to their probe specific default values thereafter. If values different from the default are required, they must be ordered as a customized parametrization → [86](#).

⁹⁾ If E and F are not specified, probe dependent default values will be used instead.

Customized parametrization If the option IJ "Customized parametrization HART", IK "Customized parametrization PA" or IL "Customized parametrization FF" has been selected in feature 570 "Service", customer specific presettings can be selected for the following parameters:



Parameter	Communication	Selection list / range of values
Setup → Distance unit	<ul style="list-style-type: none"> ■ HART ■ PA ■ FF 	<ul style="list-style-type: none"> ■ in ■ ft ■ mm ■ m
Setup → Empty calibration	<ul style="list-style-type: none"> ■ HART ■ PA ■ FF 	max. 70 m (230 ft)
Setup → Full calibration	<ul style="list-style-type: none"> ■ HART ■ PA ■ FF 	max. < 70 m (230 ft)
Setup → Adv. Setup → Current output 1/2 → Damping	HART	0 to 999.9 s
Setup → Adv. Setup → Current output 1/2 → Failure mode	HART	<ul style="list-style-type: none"> ■ Min ■ Max ■ Last valid value
Setup → Adv. Setup → Current output 1/2 → Burst mode	HART	<ul style="list-style-type: none"> ■ Off ■ On

Tagging (TAG)

Ordering feature	895: Marking
Option	Z1: Tagging (TAG), see additional spec.
Position of the measuring point marking	To be selected in the additional specifications: <ul style="list-style-type: none"> ■ Tag plate Stainless Steel ■ Self-adhesive paper label ■ Supplied label/plate ■ RFID TAG ■ RFID TAG + Tag plate Stainless Steel ■ RFID TAG + Self-adhesive paper label ■ RFID TAG + Supplied label/plate
Definition of the measuring point designation	To be defined in the additional specifications: 3 lines containing up to 18 characters each The measuring point designation appears on the selected label and/or the RFID TAG.
Designation in the Electronic Name Plate (ENP)	The first 32 characters of the measuring point designation
Designation on the display module	The first 12 characters of the measuring point designation

Services

The following services can be selected via the product structure in the Product Configurator ¹⁰⁾:

- PWIS free (PWIS: paint wetting impairment substances)
- Customized parametrization HART →  86
- Customized parametrization PA →  86
- Customized parametrization FF →  86
- Without tooling DVD (FieldCare)

¹⁰⁾ Feature 570 of the product structure

Application Packages

Heartbeat Diagnostics

Availability

Available in all device versions.

Function

- Continuous self-monitoring of the device.
- Diagnostic messages output to
 - the local display.
 - an asset management system (e.g. FieldCare/DeviceCare).
 - an automation system (e.g. PLC).

Advantages

- Device condition information is available immediately and processed in time.
- The status signals are classified in accordance with VDI/VDE 2650 and NAMUR recommendation NE 107 and contain information about the cause of the error and remedial action.

Detailed description

See Operating Instructions of the device (→  98); chapter "Diagnostics and trouble shooting"

Heartbeat Verification

Availability

Available for the following options of feature 540 "Application Package":

- EH: Heartbeat Verification + Monitoring
- EJ: Heartbeat Verification

Device functionality checked on demand

- Verification of the correct functioning of the measuring device within specifications.
- The verification result provides information about the condition of the device: **Passed** or **Failed**.
- The results are documented in a verification report.
- The automatically generated report supports the obligation to demonstrate compliance with internal and external regulations, laws and standards.
- Verification is possible without interrupting the process.

Advantages

- No onsite presence is required to use the function.
- The DTM ¹¹⁾ triggers verification in the device and interprets the results. No specific knowledge is required on the part of the user.
- The verification report can be used to prove quality measures to a third party.
- **Heartbeat Verification** can replace other maintenance tasks (e.g. periodic check) or extend the test intervals.

SIL/WHG-locked devices ¹²⁾

- The **Heartbeat Verification** module contains a wizard for the proof test which must be performed at appropriate intervals for the following applications:
 - SIL (IEC61508/IEC61511)
 - WHG (German Water Resources Act)
- To perform a proof test, the device must be locked (SIL/WHG locking).
- The wizard can be used via FieldCare, DeviceCare or a DTM-based process control system.



In the case of SIL-locked and WHG-locked devices, it is **not** possible to perform verification without additional measures (e.g. by-passing of the output current) because the output current must be simulated (Increased safety mode) or the level must be approached manually (Expert mode) during subsequent re-locking (SIL/WHG locking).

Detailed description



SD01871F

11) DTM: Device Type Manager; controls device operation via DeviceCare, FieldCare or a DTM-based process control system.

12) Only relevant for devices with SIL or WHG approval: order code 590 ("Additional approval"), option LA ("SIL") or LC ("WHG").

Heartbeat Monitoring

Availability

Available for the following options of feature 540 "Application Package":
EH: Heartbeat Verification + Monitoring

Function

- In addition to the verification parameters, the corresponding parameter values are also logged.
- Existing measured variables, such as the echo amplitude, are used in the **Foam detection** and **Build-up detection** wizards.



The **Foam detection** and **Build-up detection** wizards cannot be used together.

"Foam detection" wizard

- The Heartbeat Monitoring module contains the **Foam detection** wizard.
- This wizard is used to configure automatic foam detection, which detects foam on the product surface on the basis of the reduced signal amplitude. Foam detection can be linked to a switch output in order to control a sprinkler system, for example, which dissolves the foam.
- This wizard can be used via FieldCare, DeviceCare or a DTM-based process control system.

"Build-up detection" wizard

- The Heartbeat Monitoring module contains the **Build-up detection** wizard.
- The wizard is used to configure automatic buildup detection, which detects the buildup of deposits on the antenna on the basis of the increased area of the coupling signal. Buildup detection can be linked to a switch output in order to control a compressed air system, for example, to clean the antenna.
- This wizard can be used via FieldCare, DeviceCare or a DTM-based process control system.

Advantages

- Early detection of changes (trends) to ensure plant availability and product quality.
- Use of information for the proactive planning of measures (e.g. cleaning/maintenance).
- Identification of undesirable process conditions as the basis to optimizing the facility and the processes.
- Automated control of measures to remove foam or buildup.



Detailed description



SD01871F

Accessories

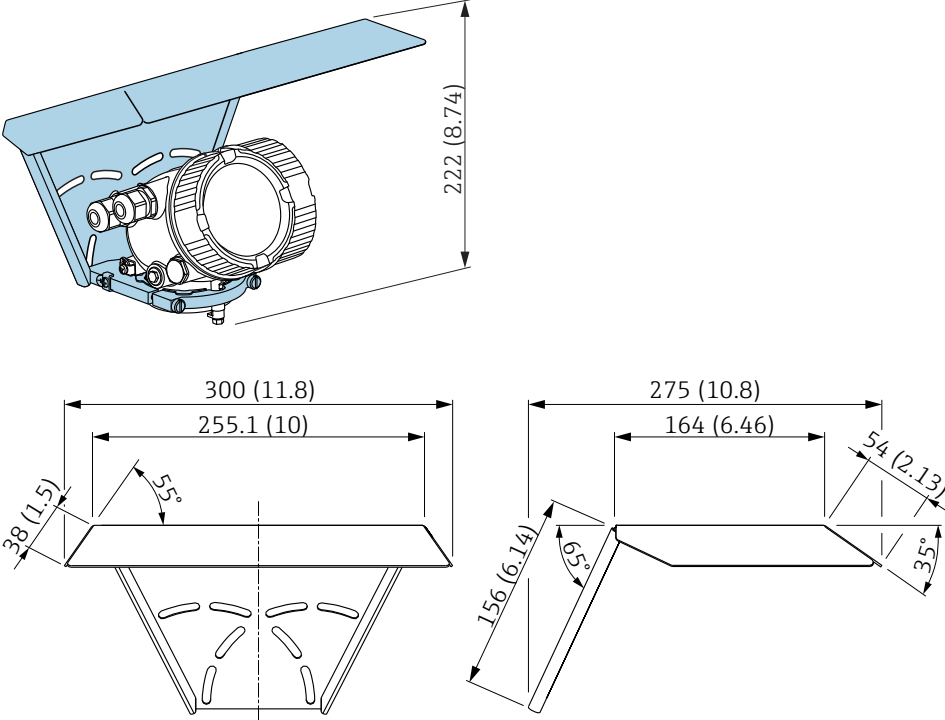
Device-specific accessories Weather protection cover

Accessory	Description
Weather protection cover	 <p data-bbox="1380 734 1436 750">A0015466</p> <p data-bbox="1380 1146 1436 1162">A0015472</p> <p data-bbox="327 1171 837 1198">  37 Weather protection cover; Dimensions: mm (in) </p> <p data-bbox="327 1227 1404 1310">  The weather protection cover can be ordered together with the device (product structure, feature 620 "Accessory Enclosed", option PB "Weather Protection Cover"). Alternatively, it can be separately ordered as an accessory; order code 71162242. </p>

Variable flange seal for FMR50/FMR56

Accessory	Description		
Variable flange seal for FMR50/FMR56	<div style="display: flex; justify-content: space-between;"> <div style="width: 45%;"> </div> <div style="width: 50%;"> </div> </div> <p style="text-align: right; font-size: small;">A0018871</p> <p>1 UNI slip-on flange 2 Variable flange seal 3 Nozzle</p> <p> The material and process conditions of the adjustable flange seal must fit the process properties (temperature, pressure, resistance).</p> <p> For FMR56: The variable flange seal can also be ordered together with the device (product structure: feature 620 "Accessory Enclosed", options PL, PM, PN, PO, PQ, PR).</p>		
Technical data: DN/JIS version			
Order code	71074263	71074264	71074265
Compatible with	DN80 PN10/40	DN100 PN10/16	<ul style="list-style-type: none"> ■ DN150 PN10/16 ■ JIS 10K 150A
Length of screws	100 mm (3.9 in)	100 mm (3.9 in)	110 mm (4.3 in)
Size of screws	M14	M14	M18
Material	EPDM		
Process pressure	-0.1 to 0.1 bar (-1.45 to 1.45 psi)		
Process temperature	-40 to +80 °C (-40 to +176 °F)		
D	142 mm (5.59 in)	162 mm (6.38 in)	218 mm (8.58 in)
d	89 mm (3.5 in)	115 mm (4.53 in)	169 mm (6.65 in)
h	22 mm (0.87 in)	23.5 mm (0.93 in)	26.5 mm (1.04 in)
h _{min}	14 mm (0.55 in)	14 mm (0.55 in)	14 mm (0.55 in)
h _{max}	30 mm (1.18 in)	33 mm (1.3 in)	39 mm (1.45 in)

Accessory	Description		
	Technical data: ASME/JIS version		
Order code	71249070	71249072	71249073
Compatible with	<ul style="list-style-type: none"> ▪ ASME 3" 150lbs ▪ JIS 80A 10K 	ASME 4" 150lbs	ASME 6" 150lbs
Length of screws	100 mm (3.9 in)	100 mm (3.9 in)	110 mm (4.3 in)
Recommended screw size	M14	M14	M18
Material	EPDM		
Process pressure	-0.1 to 0.1 bar (-1.45 to 1.45 psi)		
Process temperature	-40 to +80 °C (-40 to +176 °F)		
D	133 mm (5.2 in)	171 mm (6.7 in)	219 mm (8.6 in)
d	89 mm (3.5 in)	115 mm (4.53 in)	168 mm (6.6 in)
h	22 mm (0.87 in)	23.5 mm (0.93 in)	26.5 mm (1.04 in)
h _{min}	14 mm (0.55 in)	14 mm (0.55 in)	14 mm (0.55 in)
h _{max}	30 mm (1.18 in)	33 mm (1.3 in)	39 mm (1.45 in)

Mounting bracket for wall or ceiling mounting of FMR50/FMR56

Accessory	Description
Mounting bracket for wall or ceiling mounting of FMR50/FMR56	<div style="display: flex; align-items: flex-start;"> <div style="margin-right: 20px;"> <p>A</p> </div> <div style="margin-right: 20px;"> <p>B</p> </div> <div> </div> </div> <p> 38 Mounting bracket for FMR50/FMR56 with horn antenna</p> <p>A Mounting at ceiling B Mounting at wall</p> <ul style="list-style-type: none"> ▪ Material: <ul style="list-style-type: none"> - Mounting bracket: 304 (1.4301) - Screws: A2 - Nordlock washer: A4 ▪ Order code: 71162776

A0017746

Remote display FHX50

Accessories	Description
Remote display FHX50	<div style="text-align: center;"> </div> <p style="text-align: right; font-size: small;">A0019128</p> <ul style="list-style-type: none"> ▪ Material: <ul style="list-style-type: none"> - Plastic PBT - 316L/1.4404 - Aluminum ▪ Degree of protection: IP68 / NEMA 6P and IP66 / NEMA 4x ▪ Suitable for display modules: <ul style="list-style-type: none"> - SD02 (push buttons) - SD03 (touch control) ▪ Connecting cable: <ul style="list-style-type: none"> - Cable supplied with device up to 30 m (98 ft) - Standard cable supplied by customer up to 60 m (196 ft) ▪ Ambient temperature range: -40 to 80 °C (-40 to 176 °F) ▪ Ambient temperature range (option): -50 to 80 °C (-58 to 176 °F) ¹⁾ <p> i ▪ If the remote display should be used, order the device version "Prepared for display FHX50" (feature 030, version L or M). For the FHX50, you must select option A: "Prepared for display FHX50" under feature 050 "Measuring device version". </p> <p> i ▪ If the device version "Prepared for display FHX50" was not originally ordered and a FHX50 display is to be retrofitted, you must select version B "Not prepared for display FHX50" under feature 050: "Measuring device version" when ordering the FHX50. In this case, a retrofit kit for the device is supplied with the FHX50. The kit can be used to prepare the device so that the FHX50 can be used. </p> <p> i Use of the FHX50 may be restricted for transmitters with an approval. A device can only be retrofitted with the FHX50 if the option L or M ("Prepared for FHX50") is listed under <i>Basic specifications</i>, item 4 "Display, operation" in the Safety Instructions (XA) for the device. Also pay attention to the Safety Instructions (XA) of the FHX50. </p> <p> i Retrofitting is not possible on transmitters with: <ul style="list-style-type: none"> ▪ An approval for use in areas with flammable dust (dust ignition-proof approval) ▪ Ex nA type of protection </p> <p> i For details, see document SD01007F. </p>

1) This range is valid if option JN "Ambient temperature transmitter -50 °C (-58 °F)" has been selected in ordering feature 580 "Test, Certificate". If the temperature is permanently below -40 °C (-40 °F), failure rates may be increased.

Horn protection for horn antenna

Accessory	Description
Horn protection for 80 mm (3 in) or 100 mm (4 in) horn antenna	<p>A0019143</p> <p>A Horn antenna of the Micropilot (not supplied with the horn protection) B Horn protection ød Diameter of horn protection (see table below) øD Minimum nozzle diameter (see table below) L Length of antenna with horn protection (see table below)</p> <p>For details please refer to the Mounting Instructions SD01084F.</p> <p>Process conditions</p> <ul style="list-style-type: none"> Maximum vessel pressure: 0.5 bar (7.252 psi) Maximum process temperature: 130 °C (266 °F) <p> Danger of explosion Avoid electrostatic charging of the horn protection.</p>

Horn protection for FMR57

Antenna ¹⁾	Order code horn protection	Dimensions antenna + horn protection		
		L	Ød	ØD
BC: Horn 80mm/3"	71105890	238 mm (9.4 in)	96 mm (3.78 in)	≥ DN100
BD: Horn 100mm/4"	71105889	450 mm (17.7 in)	116 mm (4.57 in)	≥ DN150

1) Feature 070 of the product structure

 The horn protection can also be ordered together with the device. Product structure: Feature 610 "Accessory Mounted", option OW "Horn protection, PTFE".

Overvoltage protection

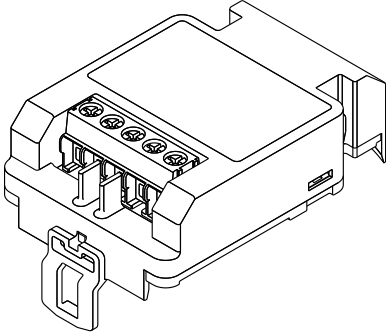
Accessory	Description
<p>Overvoltage protection for 2-wire-devices OVP10 (1 channel) OVP20 (2 channel)</p>	<div style="text-align: right; font-size: small;">A0021734</div>  <p>Technical data</p> <ul style="list-style-type: none"> ■ Resistance per channel: $2 * 0.5 \Omega_{max}$ ■ Threshold DC voltage: 400 to 700 V ■ Threshold impulse voltage: < 800 V ■ Capacitance at 1 MHz: < 1.5 pF ■ Nominal arrest impulse voltage (8/20 μs): 10 kA ■ Suited for wire cross-sections: 0.2 to 2.5 mm² (24 to 14 AWG) <p>i Ordering with device The overvoltage protection module is preferably ordered with the device. See product structure, feature 610 "Accessory mounted", option NA "Overvoltage protection". Separate ordering of the module is only necessary if a device is to be retrofitted with the overvoltage protection.</p> <p>i Order code for retrofitting</p> <ul style="list-style-type: none"> ■ For 1-channel devices (feature 020, option A) OVP10: 71128617 ■ For 2-channel devices (feature 020, option B, C, E or G) OVP20 : 71128619 <p>Housing lid for retrofitting In order to keep the necessary safety distances, the housing lid needs to be replaced if the device is retrofitted with the overvoltage protection. Depending on the housing type, the order code of the suitable lid is as follows:</p> <ul style="list-style-type: none"> ■ GT18 housing: Lid 71185516 ■ GT19 housing: Lid 71185518 ■ GT20 housing: Lid 71185516 <p>i Restrictions for retrofitting Depending on the approval of the transmitter the usage of the OVP module may be restricted. A device may only be retrofitted with an OVP module if the option NA (overvoltage protection) is quoted under <i>Optional Specifications</i> in the Safety Instructions (XA) pertaining to the device.</p> <p>i For details refer to SD01090F.</p>

Communication-specific accessories

Accessory	Description
Commubox FXA195 HART	For intrinsically safe HART communication with FieldCare via the USB interface.  For details refer to Technical Information TI00404F

Accessory	Description
Commubox FXA291	Connects Endress+Hauser field devices with CDI interface (= Endress+Hauser Common Data Interface) to the USB interface of a computer. Order code: 51516983  For details refer to Technical Information TI00405C

Accessory	Description
HART Loop Converter HMX50	Evaluates the dynamic HART variables and converts them to analog current signals or limit values. Order code: 71063562  For details refer to Technical Information TI00429F and Operating Instructions BA00371F

Accessory	Description
WirelessHART Adapter SWA70	Connects field devices to a WirelessHART network. The WirelessHART adapter can be mounted directly at a HART device and is easily integrated into an existing HART network. It ensures safe data transmission and can be operated in parallel with other wireless networks.  For details refer to Operating Instructions BA00061S

Accessories	Description
Connect Sensor FXA30/FXA30B	Fully integrated, battery-powered gateway for simple applications with SupplyCare Hosting. Up to 4 field devices with 4 to 20 mA communication (FXA30/FXA30B), serial Modbus (FXA30B) or HART (FXA30B) can be connected. With its robust design and ability to run for years on the battery, it is ideal for remote monitoring in isolated locations. Version with LTE (USA, Canada and Mexico only) or 3G mobile transmission for worldwide communication.  For details, see "Technical Information" TI01356S and Operating Instructions BA01710S.

Accessories	Description
Fieldgate FXA42	Fieldgates enable communication between connected 4 to 20 mA, Modbus RS485 and Modbus TCP devices and SupplyCare Hosting or SupplyCare Enterprise. The signals are transmitted either via Ethernet TCP/IP, WLAN or mobile communications (UMTS). Advanced automation capabilities are available, such as an integrated Web-PLC, OpenVPN and other functions.  For details, see "Technical Information" TI01297S and Operating Instructions BA01778S.



Accessories	Description
SupplyCare Enterprise SCE30B	Inventory management software that visualizes levels, volumes, masses, temperatures, pressures, densities or other tank parameters. The parameters are recorded and transmitted by means of gateways of the type Fieldgate FXA42. This Web-based software is installed on a local server and can also be visualized and operated with mobile terminals such as a smartphone or tablet.  For details, see "Technical Information" TI01228S and Operating Instructions BA00055S

Accessories	Description
SupplyCare Hosting SCH30	<p>Inventory management software that visualizes levels, volumes, masses, temperatures, pressures, densities or other tank parameters. The parameters are recorded and transmitted by means of gateways of the type Fieldgate FXA42, FXA30 and FXA30B. SupplyCare Hosting is offered as a hosting service (Software as a Service, SaaS). In the Endress+Hauser portal, the user is provided with the data over the Internet.</p> <p> For details, see "Technical Information" TI01229S and Operating Instructions BA00050S.</p>



Accessory	Description
Field Xpert SFX350	<p>Field Xpert SFX350 is a mobile computer for commissioning and maintenance. It enables efficient device configuration and diagnostics for HART and FOUNDATION fieldbus devices in the non-Ex area.</p> <p> For details, see Operating Instructions BA01202S</p>

Accessory	Description
Field Xpert SFX370	<p>Field Xpert SFX370 is a mobile computer for commissioning and maintenance. It enables efficient device configuration and diagnostics for HART and FOUNDATION fieldbus devices in the non-Ex area and the Ex area.</p> <p> For details, see Operating Instructions BA01202S</p>

Service-specific accessories

Accessory	Description
DeviceCare SFE100	<p>Configuration tool for HART, PROFIBUS and FOUNDATION Fieldbus devices</p> <p> Technical Information TI01134S</p> <p> <ul style="list-style-type: none"> ▪ DeviceCare is available for download at www.software-products.endress.com. The download requires a registration in the Endress+Hauser software portal. ▪ Alternatively, a DeviceCare DVD can be ordered with the device. Product structure: Feature 570 "Service", Option IV "Tooling DVD (DeviceCare Setup)". </p>
FieldCare SFE500	<p>Endress+Hauser's FDT-based Plant Asset Management tool. Helps to configure and maintain all field devices of your plant. By supplying status information it also supports the diagnosis of the devices.</p> <p> Technical Information TI00028S</p>

System components

Accessory	Description
Graphic Data Manager Memograph M	<p>The graphic data manager Memograph M provides information on all the relevant process variables. Measured values are recorded correctly, limit values are monitored and measuring points analyzed. The data are stored in the 256 MB internal memory and also on an SD card or USB stick.</p> <p> For details refer to Technical Information TI00133R and Operating Instructions BA00247R</p>
RN221N	<p>Active barrier with power supply for safe separation of 4 to 20 mA current circuits. Provides bi-directional HART transmission.</p> <p> For details refer to Technical Information TI00073R and Operating Instructions BA00202R</p>
RNS221	<p>Transmitter supply for 2-wire sensors or transmitters exclusively for non-Ex areas. Provides bi-directional communication using the HART communication sockets.</p> <p> For details refer to Technical Information TI00081R and Operating Instructions KA00110R</p>

Documentation



The following document types are available:

In the Download Area of the Endress+Hauser Internet site: www.endress.com → Download

Standard documentation

Micropilot FMR56, FMR57

Correlation of documentations to the device:

Device	Power supply, output	Communication	Document type	Document code
FMR56, FMR57	A, B, C, K, L	HART	Operating Instructions	BA01048F/00/EN
			Brief Operating Instructions	KA01102F/00/EN
			Description of Device Parameters	GP01014F/00/EN
	G	PROFIBUS PA	Operating Instructions	BA01127F/00/EN
			Brief Operating Instructions	KA01131F/00/EN
			Description of Device Parameters	GP01018F/00/EN
	E	FOUNDATION Fieldbus	Operating Instructions	BA01123F/00/EN
			Brief Operating Instructions	KA01127F/00/EN
			Description of Device Parameters	GP01017F/00/EN

Supplementary documentation

Application Package ¹⁾	Document type	Document code
<ul style="list-style-type: none"> ■ EH: Heartbeat Verification + Monitoring ■ EJ: Heartbeat Verification 	Special documentation	SD01871F/00/EN

1) Feature 540 of the product structure

Device	Document type	Document code
Fieldgate FXA520	Technical Information	TI369F/00/EN
Tank Side Monitor NRF590	Technical Information	TI402F/00/EN
	Operating Instructions	BA256F/00/EN
	Description of Device Parameters	BA257F/00/EN

Safety Instructions (XA)

Depending on the approval, the following Safety Instructions (XA) are supplied with the device. They are an integral part of the Operating Instructions.

Feature 010	Approval	Available for	Feature 020 "Power Supply; Output"				
			A ¹⁾	B ²⁾	C ³⁾	E ⁴⁾ /G ⁵⁾	K ⁶⁾ /L ⁷⁾
BA	ATEX: II 1 G Ex ia IIC T6-T1 Ga	<ul style="list-style-type: none"> ■ FMR56 ■ FMR57 	XA00677F	XA00677F	XA00677F	XA00685F	-
BB	ATEX: II 1/2 G Ex ia IIC T6-T1 Ga/Gb	<ul style="list-style-type: none"> ■ FMR56 ■ FMR57 	XA00677F	XA00677F	XA00677F	XA00685F	-
BC	ATEX: II 1/2 G Ex d [ia] IIC T6-T1 Ga/Gb	<ul style="list-style-type: none"> ■ FMR56 ■ FMR57 	XA00680F	XA00680F	XA00680F	XA00688F	XA00680F
BD	ATEX: II 1/2/3 G Ex ic [ia Ga] IIC T6-T1 Ga/Gb/Gc	FMR57	XA00678F	XA00678F	XA00678F	XA00686F	XA00678F
BE	ATEX: II 1 D Ex ta IIIC T ₅₀₀ xx°C Da	<ul style="list-style-type: none"> ■ FMR56 ■ FMR57 	XA00682F	XA00682F	XA00682F	XA00690F	XA00682F

Feature 010	Approval	Available for	Feature 020 "Power Supply; Output"				
			A ¹⁾	B ²⁾	C ³⁾	E ^{4)/G⁵⁾}	K ^{6)/L⁷⁾}
BF	ATEX: II 1/2 D Ex ta IIIC Txx°C Da/Db	<ul style="list-style-type: none"> ■ FMR56 ■ FMR57 	XA00682F	XA00682F	XA00682F	XA00690F	XA00682F
BG	ATEX: II 3 G Ex nA IIC T6-T1 Gc	<ul style="list-style-type: none"> ■ FMR56 ■ FMR57 	XA00679F	XA00679F	XA00679F	XA00687F	XA00679F
BH	ATEX: II 3 G Ex ic IIC T6-T1 Gc	<ul style="list-style-type: none"> ■ FMR56 ■ FMR57 	XA00679F	XA00679F	XA00679F	XA00687F	XA00679F
BL	ATEX: II 1/2/3 G Ex nA [ia Ga] IIC T6-T1 Ga/Gb/Gc	FMR57	XA00678F	XA00678F	XA00678F	XA00686F	XA00678F
B2	ATEX: II 1/2 G Ex ia IIC T6-T1 Ga/Gb ATEX: II 1/2 D Ex ia IIIC Txx°C Da/Db	<ul style="list-style-type: none"> ■ FMR56 ■ FMR57 	XA00683F	XA00683F	XA00683F	XA00691F	-
B3	ATEX: II 1/2 G Ex d [ia] IIC T6-T1 Ga/Gb ATEX: II 1/2 D Ex ta IIIC Txx°C Da/Db	<ul style="list-style-type: none"> ■ FMR56 ■ FMR57 	XA00684F	XA00684F	XA00684F	XA00692F	XA00684F
CD	CSA C/US DIP Cl.I,II,III Div.1 Gr.E-G	<ul style="list-style-type: none"> ■ FMR56 ■ FMR57 	XA01113F	XA01113F	XA01113F	XA01115F	XA01113F
C2	CSA C/US IS Cl.I,II,III Div.1 Gr.A-G, NI Cl.1 Div.2, Ex ia	<ul style="list-style-type: none"> ■ FMR56 ■ FMR57 	XA01112F	XA01112F	XA01112F	XA01114F	-
C3	CSA C/US XP Cl.I,II,III Div.1 Gr.A-G, NI Cl.1 Div.2, Ex d	<ul style="list-style-type: none"> ■ FMR56 ■ FMR57 	XA01113F	XA01113F	XA01113F	XA01115F	XA01113F
FA	FM IS Cl.I Div.1 Gr.A-D	FMR56	XA01116F	XA01116F	XA01116F	XA01118F	-
FB	FM IS Cl.I,II,III Div.1 Gr.A-G, AEx ia, NI Cl.1 Div.2	<ul style="list-style-type: none"> ■ FMR56 ■ FMR57 	XA01116F	XA01116F	XA01116F	XA01118F	-
FC	FM XP Cl.I Div.1 Gr.A-D	FMR56	XA01117F	XA01117F	XA01117F	XA01119F	XA01117F
FD	FM XP Cl.I,II,III Div.1 Gr.A-G, AEx d, NI Cl.1 Div.2	<ul style="list-style-type: none"> ■ FMR56 ■ FMR57 	XA01117F	XA01117F	XA01117F	XA01119F	XA01117F
FE	FM DIP Cl.II,III Div.1 Gr.E-G	<ul style="list-style-type: none"> ■ FMR56 ■ FMR57 	XA01117F	XA01117F	XA01117F	XA01119F	XA01117F
IA	IECEX: Ex ia IIC T6-T1 Ga	<ul style="list-style-type: none"> ■ FMR56 ■ FMR57 	XA00677F	XA00677F	XA00677F	XA00685F	-
IB	IECEX: Ex ia IIC T6-T1 Ga/Gb	<ul style="list-style-type: none"> ■ FMR56 ■ FMR57 	XA00677F	XA00677F	XA00677F	XA00685F	-
IC	IECEX: Ex d [ia] IIC T6-T1 Ga/Gb	<ul style="list-style-type: none"> ■ FMR56 ■ FMR57 	XA00680F	XA00680F	XA00680F	XA00688F	XA00680F
ID	IECEX: Ex ic [ia Ga] IIC T6-T1 Ga/Gb/Gc	FMR57	XA00678F	XA00678F	XA00678F	XA00686F	XA00678F
IE	IECEX: Ex ta IIIC T ₅₀₀ xx°C Da	<ul style="list-style-type: none"> ■ FMR56 ■ FMR57 	XA00682F	XA00682F	XA00682F	XA00690F	XA00682F
IF	IECEX: Ex ta IIIC Txx°C Da/Db	<ul style="list-style-type: none"> ■ FMR56 ■ FMR57 	XA00682F	XA00682F	XA00682F	XA00690F	XA00682F
IG	IECEX: Ex nA IIC T6-T1 Gc	<ul style="list-style-type: none"> ■ FMR56 ■ FMR57 	XA00679F	XA00679F	XA00679F	XA00687F	XA00679F
IH	IECEX: Ex ic IIC T6-T1 Gc	<ul style="list-style-type: none"> ■ FMR56 ■ FMR57 	XA00679F	XA00679F	XA00679F	XA00687F	XA00679F
IL	IECEX: Ex nA [ia Ga] IIC T6-T1 Ga/Gb/Gc	FMR57	XA00678F	XA00678F	XA00678F	XA00686F	XA00678F
I2	IECEX: Ex ia IIC T6-T1 Ga/Gb IECEX: Ex ia IIIC Txx°C Da/Db	<ul style="list-style-type: none"> ■ FMR56 ■ FMR57 	XA00683F	XA00683F	XA00683F	XA00691F	-
I3	IECEX: Ex d [ia] IIC T6-T1 Ga/Gb IEXEx: Ex ta IIIC Txx°C Da/Db	<ul style="list-style-type: none"> ■ FMR56 ■ FMR57 	XA00684F	XA00684F	XA00684F	XA00692F	XA00684F
KA	KC Ex ia IIC T6 Ga	<ul style="list-style-type: none"> ■ FMR56 ■ FMR57 	XA01045F	XA01045F	XA01045F	XA01047F	-
KB	KC Ex ia IIC T6 Ga/Gb	<ul style="list-style-type: none"> ■ FMR56 ■ FMR57 	XA01045F	XA01045F	XA01045F	XA01047F	-

Feature 010	Approval	Available for	Feature 020 "Power Supply; Output"				
			A ¹⁾	B ²⁾	C ³⁾	E ⁴⁾ /G ⁵⁾	K ⁶⁾ /L ⁷⁾
KC	KC Ex d[ia] IIC T6	<ul style="list-style-type: none"> ▪ FMR56 ▪ FMR57 	XA01046F	XA01046F	XA01046F	XA01048F	XA01046F
MA	INMETRO: Ex ia IIC T6 Ga	<ul style="list-style-type: none"> ▪ FMR56 ▪ FMR57 	XA01286F	XA01287F	XA01288F	XA01296F	-
ME	INMETRO: Ex t IIIC Da	<ul style="list-style-type: none"> ▪ FMR56 ▪ FMR57 	XA01295F	XA01295F	XA01295F	XA01299F	XA01295F
MH	INMETRO: Ex ic IIC T6 Gc	<ul style="list-style-type: none"> ▪ FMR56 ▪ FMR57 	XA01289F	XA01290F	XA01291F	XA01297F	-
NA	NEPSI Ex ia IIC T6 Ga	<ul style="list-style-type: none"> ▪ FMR56 ▪ FMR57 	XA01199F	XA01199F	XA01199F	XA01208F	-
NB	NEPSI Ex ia IIC T6 Ga/Gb	<ul style="list-style-type: none"> ▪ FMR56 ▪ FMR57 	XA01199F	XA01199F	XA01199F	XA01208F	-
NC	NEPSI Ex d[ia] IIC T6 Ga/Gb	<ul style="list-style-type: none"> ▪ FMR56 ▪ FMR57 	XA01202F	XA01202F	XA01202F	XA01211F	XA01202F
NF	NEPSI DIP A20/21 T85...90oC IP66	<ul style="list-style-type: none"> ▪ FMR56 ▪ FMR57 	XA01204F	XA01204F	XA01204F	XA01213F	XA01204F
NG	NEPSI Ex nA II T6 Gc	<ul style="list-style-type: none"> ▪ FMR56 ▪ FMR57 	XA01201F	XA01201F	XA01201F	XA01210F	XA01201F
NH	NEPSI Ex ic IIC T6 Gc	<ul style="list-style-type: none"> ▪ FMR56 ▪ FMR57 	XA01201F	XA01201F	XA01201F	XA01210F	XA01201F
N2	NEPSI Ex ia IIC T6 Ga/Gb, Ex iaD 20/21 T85...90oC	<ul style="list-style-type: none"> ▪ FMR56 ▪ FMR57 	XA01205F	XA01205F	XA01205F	XA01214F	-
N3	NEPSI Ex d[ia] IIC T6 Ga/Gb, DIP A20/21 T85...90oC IP66	<ul style="list-style-type: none"> ▪ FMR56 ▪ FMR57 	XA01206F	XA01206F	XA01206F	XA01215F	XA01206F
8A	FM/CSA IS+XP Cl.I,II,III Div.1 Gr.A-G	<ul style="list-style-type: none"> ▪ FMR56 ▪ FMR57 	<ul style="list-style-type: none"> ▪ XA01112F ▪ XA01113F ▪ XA01116F ▪ XA01117F 	<ul style="list-style-type: none"> ▪ XA01112F ▪ XA01113F ▪ XA01116F ▪ XA01117F 	<ul style="list-style-type: none"> ▪ XA01112F ▪ XA01113F ▪ XA01116F ▪ XA01117F 	<ul style="list-style-type: none"> ▪ XA01114F ▪ XA01115F ▪ XA01118F ▪ XA01119F 	-

- 1) 2-wire; 4-20mA HART
- 2) 2-wire; 4-20mA HART, switch output
- 3) 2-wire; 4-20mA HART, 4-20mA
- 4) 2-wire; FOUNDATION Fieldbus, switch output
- 5) 2-wire; PROFIBUS PA, switch output
- 6) 4-wire 90-253VAC; 4-20mA HART
- 7) 4-wire 10.4-48VDC; 4-20mA HART



For certified devices the relevant Safety Instructions (XA) are indicated on the nameplate.

If the device is prepared for the remote display FHX50 (product structure: feature 030: Display, Operation", option L or M), the Ex marking of some certificates changes according to the following table¹³⁾:

Feature 010 ("Approval")	Feature 030 ("Display, Operation")	Ex marking
BE	L or M	ATEX II 1D Ex ta [ia] IIIC T ₅₀₀ xx°C Da
BF	L or M	ATEX II 1/2 D Ex ta [ia Db] IIIC Txx°C Da/Db
BG	L or M	ATEX II 3G Ex nA [ia Ga] IIC T6-T1 Gc
BH	L or M	ATEX II 3G Ex ic [ia Ga] IIC T6-T1 Gc
B3	L or M	ATEX II 1/2G Ex d [ia] IIC T6-T1 Ga/Gb, ATEX II 1/2D Ex ta [ia Db] IIIC Txx°C Da/Db

13) The marking of certificates not mentioned in this table are not affected by the FHX50.

Feature 010 ("Approval")	Feature 030 ("Display, Operation")	Ex marking
IE	L or M	IECEEx Ex ta [ia] IIIC T ₅₀₀ xx°C Da
IF	L or M	IECEEx ta [ia Db] IIIC Txx°C Da/Db
IG	L or M	IECEEx Ex nA [ia Ga] IIC T6-T1 Gc
IH	L or M	IECEEx Ex ic [ia Ga] IIC T6-T1 Gc
I3	L or M	IECEEx Ex d [ia] IIC T6-T1 Ga/Gb, IECEEx Ex ta [ia Db] IIIC Txx°C Da/Db
ME	L or M	Ex ta [ia] IIIC T ₅₀₀ xx°C Da
MH	L or M	Ex ic [ia Ga] IIC T6 Gc
NF	L or M	NEPSI DIP A20/21 [ia D] TA, Txx°C IP6X
NG	L or M	NEPSI Ex nA [ia Ga] IIC T6-T1 Gc
NH	L or M	NEPSI Ex ic [ia Ga] IIC T6-T1 Gc
N3	L or M	NEPSI Ex d [ia] IIC T6-T1 Ga/Gb, DIP A20/21 [ia D] TA, Txx°C IP6X

Registered trademarks

HART®

Registered trademark of the FieldComm Group, Austin, USA

PROFIBUS®

Registered trademark of the PROFIBUS User Organization, Karlsruhe, Germany

FOUNDATION™ Fieldbus

Registered trademark of the FieldComm Group, Austin, Texas, USA

KALREZ®, VITON®

Registered trademark of DuPont Performance Elastomers L.L.C., Wilmington, USA

TEFLON®

Registered trademark of E.I. DuPont de Nemours & Co., Wilmington, USA

TRI CLAMP®

Registered trademark of Alfa Laval Inc., Kenosha, USA

Patents

This product may be protected by at least one of the following patents.

Further patents are pending.

US Patents	EP Patents
5.948.979	882 957
6.087.978	955 527
6.140.940	-
6.155.112	834 722
-	882 955
6.266.022	1 083 413
6.295.874	210 567
6.512.358	1 301 914
6.606.904	-
6.640.628	-
6.679.115	1 360 523
-	1 389 337
6.779.397	-
7.201.050	-
7.412.337	-
7.552.634	-
7.730.760	-
7.819.002	-
-	1 774 616
7.966.141	-
8.040.274	-
8.049.371	-



www.addresses.endress.com
